



## 2019 BEST Robotics Competition Rules

14 August 2019

### Quick Links

<a href="#">General Rules</a>		<a href="#">Judged Categories</a>
<a href="#">Consumable Kit</a>	<a href="#">Game Specific Rules</a>	<a href="#">Judged Components</a>
<a href="#">Returnable Kit</a>	<a href="#">Grid Construction Rules</a>	<a href="#">Awards</a>
<a href="#">Team Custom Parts</a>	<a href="#">Scoring Summary</a>	<a href="#">Advancement</a>

## Table of Contents

2019 BEST Robotics Competition Rules .....	1
Section 1 General Rules .....	5
1.1 Overview.....	5
1.2 Safety .....	5
1.3 Robot Design Constraints.....	6
1.3.1 Material Constraints .....	6
1.3.2 Size .....	10
1.3.3 Weight.....	10
1.3.4 Energy Sources.....	10
1.3.5 Compliance .....	11
1.3.6 General.....	11
1.4 Head-to-Head Competition Rules .....	12
1.4.1 General.....	12
1.4.2 Field Colors.....	13
1.4.3 Drivers and Spotters.....	13
1.4.4 Penalties.....	14
1.4.5 Match Protocol .....	15
1.4.6 Competition Protocol.....	16
1.5 Other Rules .....	18
Section 2 Official Kit Contents .....	19
2.1 Returnable Kit .....	20
2.2 Consumables Kit.....	23
2.3 Design and Programming Software Tools.....	28
Section 3 Game Specific Rules .....	29
3.3 Introduction .....	29
3.4 Objectives.....	29
3.5 Game Field .....	30
3.5.1 Field Layout.....	31
3.5.2 Power Grid Components.....	31
3.5.3 Transformer Skids .....	36
3.5.4 Scattered Debris.....	37
3.5.5 Debris Disposal Staging Area .....	37
3.5.6 Dumpster .....	38
3.5.7 Autonomous Vehicle Roadways.....	39

3.5.8 Robot Starting Box .....	39
3.5.9 Driver’s Box .....	39
3.5.10 Lineman & Equipment Stores Area .....	39
3.6 Game Pieces .....	39
3.6.1 Power Lines .....	39
3.6.2 Underground Conduit .....	40
3.6.3 Transformers .....	40
3.6.4 Debris .....	41
3.6.5 Autonomous Delivery Item .....	41
3.6.6 Quantity and Starting Locations .....	42
3.7 Grid Construction Rules .....	43
3.7.1 Robot Identifier Flag .....	43
3.7.2 Team Ownership .....	43
3.7.3 Remove Ground Debris .....	44
3.7.4 Attaching 345KV Transmission Lines .....	44
3.7.5 Attaching 138KV Distribution Power Lines .....	45
3.7.6 Attaching 4KV Residential Power Line .....	46
3.7.7 Install Residential Transformers .....	46
3.7.8 Install Substation Transformers .....	46
3.7.9 Installing 13KV Conduit Pipe .....	47
3.7.10 Autonomous (Driverless) Equipment Delivery .....	47
3.7.11 Interaction with Other Robots, the Field and Game Pieces .....	48
3.7.12 Driver and Lineman Rules .....	49
3.8 Scoring .....	50
3.8.1 Scoring Summary .....	50
3.8.2 Autonomous Delivery Scoring .....	51
3.8.3 Bonuses .....	52
3.8.4 Scoring Definitions .....	52
3.8.5 Sample Score Sheet .....	53
3.9 Glossary of Terms .....	54
3.10 Example Scoring Positions .....	55
Section 4 Awards and Judging .....	59
4.1 Head-to-Head Competition Judging .....	59
4.2 The BEST Award .....	59
4.2.1 Judging Evaluation and Criteria .....	60

4.2.2 Judging Procedure.....	61
4.2.3 Judging Results.....	61
4.2.4 BEST Award Recognition.....	61
4.3 Simulink Design Award.....	61
4.3.1 Applying for the Award.....	61
4.3.2 Simulink Design Award Guidelines.....	62
4.3.3 Simulink Design Award Evaluation.....	62
4.3.4 Simulink Design Award Recognition.....	63
4.4 Additional Awards.....	63
Section 5 Judged Components.....	64
5.1 Engineering Notebook (30 Points).....	64
5.1.1 Notebook Requirements.....	64
5.1.2 Notebook Evaluation.....	65
5.2 Marketing Presentation (25 Points).....	66
5.2.1 Purpose and Context.....	66
5.2.2 Marketing Presentation Guidelines.....	66
5.2.3 Marketing Presentation Logistics.....	67
5.2.4 Marketing Presentation Evaluation.....	67
5.3 Team Exhibit and Judges Interview (20 Points).....	68
5.3.1 Exhibit and Interview Guidelines.....	68
5.3.2 Exhibit and Interview Evaluation.....	69
5.4 Spirit and Sportsmanship (10 Points).....	70
5.4.1 Spirit and Sportsmanship Guidelines.....	70
5.4.2 Spirit and Sportsmanship Evaluation.....	70
5.5 Robot Performance (15 Points).....	71
5.6 BEST Robotics Brand Usage Guidelines for Teams.....	71
Section 6 Advancement to Regional Championship Competition.....	72
Section 7 Standard Required Awards.....	73
7.1 Hub-Level Awards.....	73
7.2 Regional Championship Awards.....	73

## Section 1 General Rules

### 1.1 Overview

This is a student-oriented contest. The students will gain the most if they do the work. Mentors and coaches are to provide guidance only and not to make parts, detail design, nor force their will on the students.

The rules governing the BEST competition consist of the following:

1. Section 1 BEST General Rules
2. Section 2.1 Returnable Kit List
3. Section 2.2 Consumable Kit List
4. Section 3 Game Specific Rules (may supersede Generic Rules)
5. On-line Question and Answer (Q&A) system

Most questions about the game can be answered by first **READING THE RULES THOROUGHLY**. All questions concerning these rules (during the 6-week design and construction phase, not during the competition) must be submitted to the Game Committee in writing through the web-based interface at <http://www.bestinc.org>. All questions and answers will be distributed to all teams via the web. Responses to the posted questions on the web site are an extension of the rules. In the event of contradiction between the rules and the Q&A responses, the Q&A responses supersede the rules.

### 1.2 Safety

Safety may not and will not be compromised.

1. Safety is a priority.
2. The referees will disqualify any machine that appears to be a safety hazard.
3. Batteries, chargers, and other components of the BEST Control System Kit may not be tampered with or altered in any way.
4. Except for a power drill/driver and a soldering iron/gun (electrically powered only), no power tools (including battery operated) will be allowed in the pit area during any BEST activity. Common hand tools will be allowed. The power drill/driver may be used for drilling and/or hardware insertion/removal, but not for grinding, sawing, routing, etc. The allowed power tools can be operated only in the pit area or in the hub designated workstation area.
5. All individuals working on the machine in the pit area must wear safety gear appropriate to the activity (e.g., safety glasses should be used when soldering or drilling).
6. Any illegal tools may be confiscated for the day.

## 1.3 Robot Design Constraints

### 1.3.1 Material Constraints

Each team receives two kits: a Returnable Kit and a Consumable Kit. Each machine must be constructed using only the materials that appear on the returnable and consumable kit lists (provided in Section 2). Exceptions to this rule are described in [Section 1.3.1.4](#).

The Returnable Kit List and Consumable Kit List are the official references for parts; therefore, they define the type and quantity of parts that can legally be used on the machine. The team is responsible for confirming that items in the received kits are consistent with the items on the lists and include no excess parts. Excess parts may not be used.

#### 1.3.1.1 Construction Requirements

1. All robot construction is to occur after the hub Game Kickoff event has been held. There should be no part construction prior to the Game Kickoff event nor reuse of parts from previous competitions. Robot parts may be permanently marked (via scribing, drilling holes, etc.) by BEST personnel in order to prevent reuse.
2. There are no restrictions on the tools or machines that are used to create parts; however, there is still the expectation that students will be taught how to use these tools/machines and that they will be the ones using and operating them in the fabrication of the parts.
3. The VEX Cortex microcontroller and battery must be secured to the robot. The Cortex microcontroller must be mounted to your robot through the holes provided on its base (suggest using #8 machine screws to avoid damaging the Cortex).

#### 1.3.1.2 Returnable Kit

1. All Returnable Kit items, including boxes and packing, **must be returned** at the conclusion of the contest in the same condition as received except as noted in item 2 below.
2. Returnable Kit equipment cannot be modified in any way, with the following exceptions:
  - a. The belt stock supplied in the returnable kit may be modified as needed (e.g., cut, holes punched, etc.); however, the belt that is provided as loop may not be modified.
  - b. Servo horns may be modified as desired.
  - c. BEST IR Sensor Kit may be assembled.

3. The Returnable Kit List specifies certain items that may not be attached to the machine (e.g., the battery chargers).
4. The motors and servos may not be opened for any reason. For example, it is illegal to change the gearing or to re-wind the armature of any motors.
5. The pulleys, bearings, and shoulder screw included in the return kit may not be modified. You may not use any glue or adhesive tape on these items.
6. Tape/adhesive/glue may not be applied to any returnable item unless specifically allowed (see [Section 1.3.1.4](#)). The adhesive portion of the supplied Velcro™ brand hook and loop fastener may not be attached to the battery or to any other returnable item.
7. Paint may not be applied to any Returnable Kit item.
8. The VEXnet Joystick, servos, VEX Cortex microcontroller, VEXnet Keys, batteries, and battery chargers may not be tampered with, modified, or adjusted in any way. The only exception is that the VEX Cortex microcontroller may be programmed as desired.
9. Teams may not put labels or rubber bands on the VEXnet Joystick, nor make internal, reversible modifications to the joysticks.
10. Wires may be soldered to the motor power lugs.
11. Only the screw terminal motor interface cables, motor controllers or the servo power adapter cables may be plugged directly into the VEX Cortex microcontroller motor ports. Motor ports 1 and 10 cannot be used (do not plug the screw terminal motor interface cables into these ports). Only the screw terminal sensor interface cables (3-wire) or the cables from the BEST IR Sensor Kit may be plugged directly into the VEX Cortex microcontroller digital/analog input/output ports. No other connection methods to the Cortex may be used. Soldering to the Cortex microcontroller or to any of the interfacing cables is not allowed.
12. The BEST-supplied 7.2 Volt NiMH 3000maH batteries are the only allowed source of electrical power for the functional components of your entire machine.
13. The 7.2 Volt batteries may **only** be connected to the VEX Cortex microcontroller through the supplied mating connectors. Do not attempt to connect the 7.2 Volt batteries to any other Cortex input other than the battery connector. Do not attempt to connect the 7.2 Volt batteries to any item/circuit other than the Cortex microcontroller.
14. Only one 7.2 Volt battery may be used on the machine during a match. Even if unconnected, the other battery may not be on the machine.
15. On Game Day, replacement batteries will only be provided upon proof of battery failure (e.g., a bad connection) on an exchange basis (you must turn in the faulty battery).
16. You must play all your Game Day matches using the 7.2 Volt batteries supplied by BEST. Team-owned batteries (that power the robot) and team-owned battery chargers for the 7.2V batteries

are not allowed on the field or in the pit area on Game Day; however, team-owned batteries are allowed during other BEST activities.

17. You may use the provided AAA rechargeable batteries or team provided batteries in the VEX Joystick.

### 1.3.1.3 Consumable Kit

1. Consumable Kit parts may be modified as desired within the constraints of these rules.
2. Limited numbers of replacement parts may be available from your local hub, upon a justified request. Otherwise, lost or damaged kit material may only be replaced with identical components. Replacement parts purchased by the team must have the same:
  - a. material as the kit part;
  - b. treatment or grade as the kit part; and;
  - c. dimensions as the kit part.

e.g. a 1x4 may **not** be replaced with a 2x4 of the same total volume.
3. The Consumable Kit list identifies optional items that may be provided by the team and used on the machine.
4. Team supplied pennies may not be altered.
5. The only Consumable Kit items that may be used to conduct electricity are the provided wire, the snap-plug terminals or the (optional) quick-disconnect terminals (and also soldering material at the wiring connections). The only exception is that any of the Consumable Kit provided/allowed metallic materials may be used as part of a sensor circuit.
6. No package materials may be used (materials that come with kit items to protect or store them before use). Examples: The plastic film that covers the adhesive portion on the hook and loop strip; cardboard roll at the center of a tape roll.

### 1.3.1.4 Additional Materials, Constraints and Exceptions

1. Lubricants may be used for lubrication only. A machine may not intentionally contaminate the playing field or an opponent's machine with lubricant.
2. Paint, stickers, and/or decals may be used on the robot as decorations only. They cannot be applied to any of the returnable items. Paint or finish cannot be used to change the mechanical properties of what it is applied to. The colors of paint/finish that are used on the machine are not considered in a functionality determination. For example, some item on the machine could be painted neon orange to increase its visibility.
3. Other non-functional decorations are only permitted if they do not aid the machine in performing the game tasks. If you can remove it or cover it up (and you may be asked to) and



your machine behaves the same, it is probably non-functional. Lights can be added to the machine, but no strobe lights are allowed.

4. Video capture devices (like a GoPro or a phone) are allowed on the robot subject to the rules for decorations and with the additional rules listed below:
  - a. display screen cannot exceed 6" diagonal
  - b. display must be turned off or covered up
  - c. non-BEST kit mounting brackets/hardware are considered to be a part of the device
  - d. recommend that device be protected from possible contact with field or other robots (BEST not responsible for any damage that occurs to the device during game play)
  - e. device cannot be transmitting a signal (no streaming)
  - f. BEST officials may ask for the device to be removed at any time for any reason
5. Non-functional decorations may use a separate power source (e.g., 9V battery).
6. The use of markers/paint/printouts may be used to provide visual information that does not aid the team in performing the game tasks. Examples of what is allowed would be things such as labeling machine parts with a marker, placing a copy of the Cortex port use schematic on the machine, and so on.
7. You may solder electrical wire connections using your own solder except where electrical connectors are provided. Where connectors have been provided (i.e., on the VEX Cortex microcontroller, servo power adapter cables, servo extension wires, batteries and other returnable items), they must be used without soldering to the connector. Solder may be applied to connectors included in the Consumable Kit (e.g., bullet connectors or quick-disconnect connectors).
8. No welding, brazing or structural soldering is allowed.
9. Metal, rubber, and plastic items may be heated and reformed, but may not be melted and re-cast.
10. Materials may not be changed chemically. The exceptions are that strings and the outer sheath of the shock cord may be singed to prevent loose ends and that kit allowed resin and hardener may be mixed to result in epoxy.
11. Residue-free "painters" tape (supplied in the Consumable Kit) may be used on any Returnable Kit items except the Joystick.
12. Thread locker may be used on Consumable Kit fasteners.

### 1.3.1.5 Team Custom Parts

Two Team Custom Parts (TCP) are allowed.

1. Each part can be made from any uniform (homogeneous) team supplied material.
2. Each part must be able to fit, unconstrained, into a 2" x 4" x 4" cuboid.
3. Each part must be a single continuous piece of material (when in its operational state).
4. The basic raw stock form of the chosen material must be used for the part. The starting raw stock must be rectangular or cylindrical material if the final part retains any of the original raw stock shape. Material starting shape is irrelevant for parts that are in a liquid state in the forming process or if the final part is completely carved/machined from a solid block of the material.
5. No other kit parts may be embedded in a TCP.
6. No hazardous materials are allowed (rule 1.2 item 2 still applies).
7. No welding is allowed (rule 1.3.1.4 item 8 still applies).
8. Melting is allowed (rule 1.3.1.4 item 9 is waived).
9. Chemical change is allowed (rule 1.3.1.4 item 10 is waived).

### 1.3.2 Size

1. At the start of each match, the machine must fit, **unconstrained**, within a cubic space that is 24 inches on a side (machine can be powered on during this check). The machine must remain within the maximum size limit, unconstrained, until the beginning of the match.
2. Once the match begins, the machine may unfold and change size through its own power.
3. There is no size requirement at the end of the match (i.e., the machine does not have to return to its initial configuration).

### 1.3.3 Weight

1. The weight of the machine may not exceed 24 pounds, including the battery and all parts and devices of your machine (e.g., detachable pieces, optional equipment, tethered parts, decorative items, etc.).

### 1.3.4 Energy Sources

1. The energy used by the machine must come solely from:
  - a. electrical energy derived from the single onboard battery pack;
  - b. storage achieved by the deformation of the springs provided in the kit or springs created per the Team Custom Part rules;
  - c. a change in the altitude of the center of gravity of any part of the machine; and/or;

- d. stretched items (inner tube/rubber bands/shock cord/TCP) are allowed provided that the part is attached to the machine so that it will not fly off if broken

### 1.3.5 Compliance

1. All machines will be inspected for compliance with the regulations before the competition. Machines must meet these regulations to qualify for the competition. The winning machines may be inspected again following the competition. Failure to comply with the regulations will result in disqualification.
2. No substitute machines are allowed. Machines may be modified between matches but must still meet all the regulations after the modifications are made. The compliance official must approve all modifications prior to the team's next match of competition.
3. Random re-checks of machines will be performed throughout the day at the discretion of the referees. Any machine found to be non-compliant will not be allowed to continue the competition until brought into compliance and may be disqualified from prior matches.
4. The machines may not leave the competition site between the time they are checked for compliance and the start of the competition without approval from the competition officials.
5. Teams that place high enough to advance to a regional/national championship are allowed to make repairs and/or functional improvements to their machine. Machines will be rechecked for compliance prior to the regional/national championship competition.
6. A machine may have multiple configurations, like different arms that can be swapped-out. Each configuration must meet size and weight requirements independently and be approved through a compliance check. The sum total of all parts and materials from all of the configurations cannot exceed the quantities defined by the Returnable and Consumable Kit Lists.

### 1.3.6 General

1. Machines must be designed to operate by reacting only against the surfaces of the playing field (including the PVC pipes, ramps, etc.), the opponents' machines, and the air. Machines are allowed to clamp to anything in the field except another machine.
2. During a match, the machine may only be controlled through normal operation of the VEXnet system. Touching the robot will result in penalty or disqualification as described in [section 1.4.3](#) and the [Game Specific Rules](#).
3. No external devices may be connected to the joystick during match play unless specifically provided by BEST competition personnel (things such as an auxiliary power supply or a channel shifting dongle).
4. Machines must prominently display their team number.
5. Powered tandem devices are permitted and may use an umbilical to connect the two devices. This umbilical is considered part of the machine and is subject to the same constraints as the rest of the machine.

6. All projectiles must have a frontal area greater than 10 square inches. A projectile is anything launched through the air, whether free flying or tethered. Parts that detach or fall from a machine and remain on the playing surface are not considered projectiles.
7. Gaining traction or gripping game pieces through the use of adhesives, or by abrading or breaking the surface of the field is not allowed. The friction tape (either side) from the Consumable Kit is not considered an adhesive and is allowed (actually intended) for gripping.
8. Spiked wheels are allowed only if the portion of the spike in contact with the field has at least one dimension greater than ¼ inch.
9. Strategies aimed only at destruction, damage (e.g., stabbing, cutting, etc.), over-turning, or entanglement of an opponent's machine are not in the spirit of the competition and are not allowed. Turning over an opponent's machine may or may not result in a penalty depending on the opinion of the referees. Review section [1.4.3](#) for a description of penalties for overly aggressive actions.
10. Machines may deploy detachable components on the field. A component is considered “detached” if it has no kit parts connecting it, directly or indirectly, to the set of kit parts that includes the battery. Such components may be used to capture, contain, manipulate game pieces, and/or block another machine. Such components may not be launched at, deliberately attached to, or otherwise deliberately used to entangle another machine. Incidental contact between any machine and such detachable components after deployment will not result in a penalty for any team. Detached components will not count as “part of the machine” unless otherwise stated.
11. Following the competition, all items provided in the Returnable Kit must be returned to the hub (local BEST organization). The rest of the machine may be retained by its respective school.

## 1.4 Head-to-Head Competition Rules

### 1.4.1 General

1. Referees have ultimate authority during the competition. No protests will be allowed.
2. On Game Day there will be individuals identified as Team Advocates to answer questions about the game or rules. Do not approach referees, scorekeepers or other officials with questions.
3. A referee, at their discretion, may untangle machines that become entangled with part of the field, or each other, for more than 10 seconds or that may appear to be damaging the field because of the entanglement. A machine that is high-centered on an element of the field or on a game piece is not considered entangled. A machine that has tipped over is not considered entangled. A referee may ask the driver to quit attempting to free their machine if the field is at risk of being damaged.

### 1.4.2 Field Colors

Specific team locations on the field (e.g., driver/spotter locations, robot starting area, allowed team maneuvering areas, team scoring areas, etc.) are designated through the following four-color scheme.

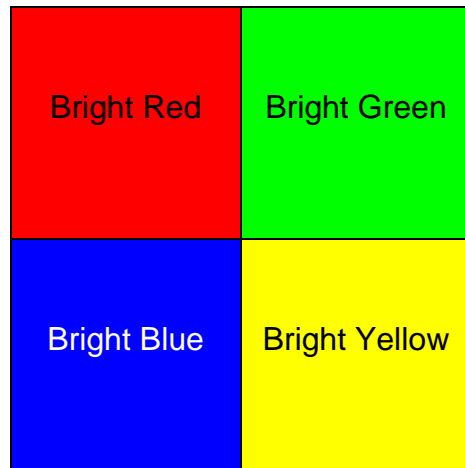

### 1.4.3 Drivers and Spotters

1. During a match, only one student member of each team is allowed in the team driver's area and one student member is allowed in the team spotter's area. Adult coaches and teachers are not allowed in either of the areas during matches. Students are not allowed to stand on platforms of their own construction (or each other) to get a better view. A hub may, on a case-by-case basis, make unique provisions for special needs drivers/spotters as deemed appropriate.
2. Only one person per match is allowed to drive the machine (i.e., operate the VEXnet Joystick). Prior to the competition, each team must submit a driver list to the organizers. The minimum number of student team members on the driver list is shown in the following table:

Student team members <b>present</b> at competition	<b>Minimum</b> number of students on driver roster
2-4	2
5-6	3
7-8	4
9 or more	5

*Please note that the previous table reflects the minimum number of drivers required; BEST encourages participation by as many team members as possible. Also note that the*

*number of student team members present at the competition is used to determine the minimum number of drivers on the list.*

3. The first person on the driver list is the driver for the first match; the second person on the list is the driver for the second match, etc. This rotation will continue for successive matches until the list is exhausted, at which time the rotation will start again at the top of the list. Rotation in successive phases of the competition (e.g., seeding, semi-finals, and finals) will begin where the previous phase rotation left off. If the organizers eliminate a match for any reason, the driver rotation will continue in accordance with the driver list with the driver scheduled for the eliminated match (or matches) being the first driver for the following match.
4. The spotter may be any student from the team.
5. Spotters and drivers are not allowed to handle the game pieces prior to a match.
6. During a match, spotters and drivers may not communicate with anyone through the use of any electronic devices or other signaling technique that involves a signaling aid that is not part of the human body (e.g., signs, sticks, marked gloves, etc. are not allowed).

#### 1.4.4 Penalties

1. A 20-second suspension may be assessed for a variety of infractions that are detailed below and in Section 3 (Game Specific Rules) of this document. This penalty requires the driver to surrender their VEXnet Joystick to a referee for a period of 20 seconds. The referee will return the joystick to the driver upon expiration of the penalty and the machine may continue the match. Penalty decisions of the referees will be final.
2. If a driver touches their own machine before any part of it has left the starting area, a 20-second penalty will be assessed after contact ceases. Machine contact within the starting area is allowed only for the purpose of debugging a defective machine (e.g., turning on the on/off switch). If a spotter or driver otherwise touches their own or another team's machine, the machine of the individual doing the touching will be disqualified.
3. Spotters and drivers are not allowed to enter the field during a match. If a spotter or driver enters the field during a match, their machine will be disqualified.
4. If a spotter or driver leaves the designated spotter or driver area, a 20-second penalty will be assessed as described in item 1 of this section.
5. Machines that touch the ground outside the field boundary will be assessed a 20-second penalty as described in item 1 of this section. Machines that completely leave the field will be stopped for the duration of the match.
6. Damaging any portion of the field or game pieces may result in disqualification. Intentionally moving or tipping over static portions of the field is considered damaging the field and will result in disqualification.

7. Referees may instruct the driver of an aggressive machine to cease an action if the referee feels that another machine or the field may be damaged by that action. Referees will disqualify a team from a match if a major breach of the rules occurs.
8. Disqualification is on a match basis, except for non-complaint machines as noted in [Section 1.3.5](#). Any team that is disqualified will receive zero points for that match.

### 1.4.5 Match Protocol

1. There will be at least five referees during each match. The Head Referee will act as timekeeper and the other four referees will monitor each of the teams.
2. Each match will be three minutes long and will be played with four teams, if possible. The scoring software will assign teams to a match and will determine the team's quadrant/color for each match.
3. Teams will be notified of their field and position assignment at least two minutes before the match. Teams must be in the staging area at the end of the preceding match.
4. Prior to the beginning of the match, teams must wait at the designated staging area until the beginning of the setup period. Once signaled, teams have the duration of the setup period to place their robot into a valid starting position. Refer to [Section 3](#) to clarify valid starting positions.
5. As a guide, a maximum setup time of 30 seconds will be allowed once the team arrives at the field. If a team has not successfully placed their robot by the end of the setup period, the head referee has discretion to allow the team to continue to place their robot and assess a 20-second penalty to be applied at the beginning of the match or whenever the team is ready to begin play.
6. At the start of each match, the machine must be placed at the designated starting area. The spotter or driver may enter the field prior to the start of the match to place the machine in its starting location and prepare it for the match. Temporary alignment marks on the field are not permitted. Additional team members may be allowed to assist in setting up the machine but must leave the field area prior to the start of the match.
7. The machine, driver and spotter must be in the designated location(s) at the start of the match to score any points during the match. The driver and spotter must remain in the designated areas during the match.
8. A maximum of 30 seconds will be allowed at the end of each match for removal of the machines. Additional team members may be allowed to assist in removing the machine.
9. At the end of the match, the driver and spotter must remain in the designated areas until referees have completed scoring of the match and indicated that robots may be removed.
10. Following the match, the referee will review the scored items with the driver; the driver will sign the scorecard indicating agreement.

## 1.4.6 Competition Protocol

There will be four phases to the head-to-head competition:

- a seeding phase,
- a wildcard phase,
- a semi-final phase, and
- a finals phase.

This protocol will be the same for both hub contests and championships.

Section 3 Game Specific Rules define any tiebreakers for determining which team advances from one phase to another in the event of a tie. If no tiebreaker is identified, the default method will be 1) Engineering Notebook scores, 2) head-to-head match results, 3) Coin toss, in that order.

### 1.4.6.1 Seeding Phase

The Seeding Phase will consist of a round robin competition among all participating teams. Each team will participate in up to eight matches against randomly selected opponents. Fewer than eight matches per team may be played when time limitations exist, but no fewer than five matches. All teams will participate in the same number of matches. Match scheduling will attempt to ensure that each team plays on each quadrant of the field and that back-to-back matches are limited.

The team ranking during this phase will be based on the average of the points scored during the seeding matches excluding the teams' lowest match score. Consult Section 3 Game Specific Rules for any variation to this ranking method.

For competitions with 32 or fewer teams, the top 7 teams from the seeding phase will automatically advance to the semi-finals phase. The final team to advance into the semi-finals phase will be selected from the remaining teams during the "Wildcard Match Phase".

For competitions with greater than 32 teams, the top 14 teams from the seeding phase will automatically advance to the semi-finals phase. The final two teams to advance into the semi-finals phase will be selected from the remaining teams during the "Wildcard Match Phase".

### 1.4.6.2 Wildcard Match Phase

For competitions with 32 or fewer teams, the wildcard phase will consist of a single match between the four (4) teams with the highest BEST Engineering Notebook scores, who have not automatically advanced to the semi-final phase. The team achieving the highest score during the wildcard phase will advance to the semi-finals.

For competitions with greater than 32 teams, the wildcard phase will consist of two matches between the eight (8) teams with the highest BEST Engineering Notebook scores who have not automatically advanced to the semi-final phase. This phase will consist of 2 matches of 4 teams (as all matches are limited to 4 teams), which may be played in parallel. The two (2) teams achieving the highest scores during the wildcard phase will advance to the semi-finals.



The wildcard phase will be conducted according to the rules for the seeding phase. Each wildcard team will play in only one match during this phase.

### 1.4.6.3 Semi-Finals Phase

During the semi-finals phase, each team will participate in three (3) matches based on the rotation shown in Table 1 or 2. The team ranking at the end of the semi-finals will be based on the total points each team accumulated during their three matches. No scores will be dropped and the scores from all previous phases will be disregarded. Game play will be the same as previously described for the seeding phase. Only the top four (4) ranked teams from the semi-finals phase will advance to the finals, regardless of the number of teams competing in the semi-finals.

**Table 1. Field Position Assignments for 8-team Semi-Finals**

Semi-Final Match	Field Position Assignment			
	Yellow	Blue	Red	Green
1	Seed 4	Seed 6	Seed 3	Seed 2
2	Seed 7	Seed 1	Seed 5	Seed 8
3	Seed 3	Seed 7	Seed 8	Seed 4
4	Seed 6	Seed 5	Seed 2	Seed 1
5	Seed 5	Seed 3	Seed 6	Seed 7
6	Seed 8	Seed 2	Seed 1	Seed 4

**Table 2. Field Position Assignments for 16-team Semi-Finals**

Semi-Final Match	Field Position Assignment			
	Yellow	Blue	Red	Green
1	Seed 4	Seed 13	Seed 1	Seed 16
2	Seed 5	Seed 10	Seed 3	Seed 15
3	Seed 6	Seed 9	Seed 8	Seed 11
4	Seed 16	Seed 4	Seed 2	Seed 14
5	Seed 8	Seed 5	Seed 6	Seed 12
6	Seed 7	Seed 11	Seed 9	Seed 10
7	Seed 3	Seed 14	Seed 13	Seed 2
8	Seed 10	Seed 12	Seed 5	Seed 1
9	Seed 15	Seed 6	Seed 16	Seed 7
10	Seed 14	Seed 8	Seed 11	Seed 13
11	Seed 1	Seed 7	Seed 4	Seed 3
12	Seed 2	Seed 15	Seed 12	Seed 9

### 1.4.6.4 Finals Phase

The four (4) top ranked teams will participate in three (3) matches during the finals phase. Field assignments per match will rotate as shown in Table 3. The final team ranking will be based on the total points accumulated by the team during these 3 finals matches. No scores will be dropped and the scores from all previous phases will be disregarded. Game play is the same as

previously described for the seeding phase. The winner is the team with the most points accumulated during the three final matches.

**Table 3. Field Position Assignments for Finals**

Final Production Match	Field Position Assignment			
	Yellow	Blue	Red	Green
1	Semi-Final 1	Semi-Final 2	Semi-Final 3	Semi-Final 4
2	Semi-Final 4	Semi-Final 3	Semi-Final 2	Semi-Final 1
3	Semi-Final 3	Semi-Final 1	Semi-Final 4	Semi-Final 2

## 1.5 Other Rules

1. Student eligibility is left to each individual school.
2. All contestants on the gym floor must wear shoes appropriate to the gym floor surface as determined by the sponsoring BEST organization.
3. Each team will be provided with their own workspace in the pit area in which they may place a table with a surface area no greater than 2400 square inches, if a table is not provided by the hub. Each team will have access to one electrical plug for battery charging. The exact specifications may vary from hub to hub.
4. Each team may bring a toolbox with basic hand-tools subject to the safety constraints listed in [Section 1.2](#). If a part is broken during competition and the team cannot repair it with tools or material they have, consult the sponsoring BEST organization. They will make their best effort to help the team replace the part, given local shop and/or spare material availability.
5. At least one practice day will be available preceding Game Day. Consult the sponsoring BEST organization for times and locations. Tables and electricity will be available on a shared basis and teams must provide their own tools. The same safety rules apply to practice days as they do during the competition.

## Section 2 Official Kit Contents

The official BEST Kit Lists are shown on the following pages. Refer to section 1.3.1 for details regarding Kit constraints and usage. Each machine must be constructed using only the materials (quantity, type and grade) that are on the returnable and consumable kit lists. The ONLY exceptions are described in Section 1.3.1.4.

## 2.1 Returnable Kit

## 2019 BEST Returnable Kit List

	Check	Qty	Item Description	Required/Optional	Source	Part Number
<b>BEST Control System Kit (VEX 270-1605)</b>		1	Cortex Microcontroller	Req'd <sup>3</sup>	VEX Robotics	278-2194
		1	VEXnet Joystick	Req'd	VEX Robotics	276-2192
		2	VEXnet Key 2.0	Req'd	VEX Robotics	276-3245
		4	Motor Controller 7.2V 4A	Req'd	VEX Robotics	276-2193
		2	Large Motor	Req'd	VEX Robotics	276-1611
		2	Small Motor	Req'd	VEX Robotics	276-1610
		2	7.2 V 3000 mAh NiMH battery - modified w/ PowerPoles	Req'd <sup>1</sup>	VEX Robotics	276-1491
		2	Charger Adapter (for Cortex and Battery Charger)	Req'd <sup>2,3</sup>	None - Hub Assy Req'd	n/a
		8	Screw Terminal Sensor Interface Cable 3-wire	Req'd <sup>4</sup>	VEX Robotics	276-3071
		4	Screw Terminal Motor Interface Cable (red and black wires)	Req'd	VEX Robotics	276-1608
		4	Servo Power Adapter Cable	Req'd	VEX Robotics	276-2195
		1	Smart Battery Charger & power cord	Req'd <sup>2,3</sup>	VEX Robotics/Other	276-2519, 276-2520
		1	8-bay AAA Smart Battery Charger & power cord	Req'd <sup>2</sup>	VEX Robotics/Other	276-1622
		6	AAA NiMH Rechargeable Batteries (installed in Joystick)	Req'd	VEX Robotics/Other	276-1696
	1	USB A-A Cable	Req'd <sup>2</sup>	VEX Robotics/Other	276-1403	

	Check	Qty	Item Description	Required/Optional	Source	Part Number
<b>BEST Servo Kit (VEX 270-1682)</b>		4	Futaba 3003/3004 or HiTec HS-425BB Servos	Req'd	various	
		4	servo horn screw	Req'd	various	
		5	Servo horn (radius not to exceed 1")	Req'd	various	
		2	24" servo extension cable (600 mm also allowed)	Req'd	various	
		2	40" servo extension wire (36" or 1000 mm also allowed)	Req'd	various	
		16	rubber grommet	Opt <sup>5</sup>	various	
		16	brass spacer	Opt <sup>5</sup>	various	
		16	servo mounting screw	Opt <sup>5</sup>	various	
<b>BEST Motion Components Kit (VEX 270-4395)</b>		1	1/4" bore, 24 tooth, (small) drive pulley	Req'd	VEX Robotics	270-4395
		1	1/4" bore, idler (dia. to match 24 tooth pulley)	Req'd	VEX Robotics	
		1	1/4" bore 120 tooth, (large) drive pulley	Req'd	VEX Robotics	
		1	170 tooth, 3 mm pitch, 9 mm wide HTD loop belt	Req'd	VEX Robotics/Other	
		1	3 mm pitch, 9 mm wide HTD strip belt, 3 ft long	Req'd	VEX Robotics/Other	
		1	1/4" dia. shoulder screw w/ #10-32 thread	Req'd	VEX Robotics	
		1	76mm roller blade wheel (78A to 82A) w/ bearings and 6mm spacer	Req'd	VEX Robotics/Other	
		1	6mm roller blade wheel axle (any style)	Req'd	VEX Robotics/Other	
		4	R4AZZ Ball Bearing (0.25 ID x 0.75 OD x 0.28 wide)	Req'd	VEX Robotics/Other	

	Check	Qty	Item Description	Required/Optional	Source	Part Number
<b>Hub Provided</b>		1	spare (replacement) servo horn screw	Req'd	various	
		3	BEST IR Sensor Kit	Req'd	BEST Robotics	
		3	6" servo extension cable (150mm, 8" or 200mm also allowed)*	Req'd	various	
		3	24" servo extension cable (600 mm also allowed)*	Req'd	various	
		1	18" (or less) USB extension cable (between Cortex and VEXnet key)	Opt <sup>5</sup>	monoprice	5431
		1	VEX Programming Hardware Kit	Opt <sup>2,5</sup>	VEX Robotics	276-2186
		2	Metal wheel hubs (1.5" max dia, 0.5" max thk, 0.250" bore, with set screw)	Req'd	VEX Robotics	270-6430
		2	window alarm sensor	Req'd	McMaster-Carr	8039A12
		2	1/4" shaft coupler, with set screws	Req'd	McMaster-Carr	6412K11
		any	containers, bags, boxes	Req'd <sup>2</sup>	Hub Supplied	

Notes: <sup>1</sup> Only one battery can be used on the robot at any given time.

<sup>2</sup> These items cannot be used on the robot.

<sup>3</sup> Cortex and battery charger may be converted (by the Hub only) to PowerPole connectors, eliminating the need for the adapters.

<sup>4</sup> Up to (6) of the three wire sensor interface cables(VEX P/N 276-3071) may be sub'd with old style two-wire sensor cables (VEX P/N 276-1734). A total of (8) sensor interface cables are required.

<sup>5</sup> Teams may use these Returnable Kit optional items even if they are not supplied by their Hub.

\* Any shroud protecting the male pins must be removed (so it can be plugged into Cortex).

2.2 Consumables Kit

2019 BEST Consumable Kit List (provided by hub)

Type	Check	Qty	Item Description
igus® Donated Parts		1 meter	Energy Chain, P/N E2-15-20-028-0, w/ 2 each mount brackets (P/N E2.150.20.1 & .2)
		2 ea	DryLin® N Linear Guide system, P/N NK01-27-2-450
		6 ea	igubal® Flange Mount Spherical Bearing, 1/4", P/N EFOI-04
		6 ea	igubal® Pillow Block Mount Spherical Bearing, 1/4", P/N KSTI-04
		6 ea	iglide® G300 Flanged Bushing, 1/4", P/N GFI-0405-06
		6 ea	igubal® 1/4" Rod End Bearing, 1/4"-28 Thread, P/N EBRI-04
		2 ea	DryLin® S, 1/4" diameter, hard anodized Aluminum Shaft, P/N AWI-04, 18 inch length
Plastic and Metal Stock		1 ea	3/16" thick corrugated plastic, 12" x 24" (donated by Inteplast Group)
		1 ea	1/4" thick polypropylene sheet, 12" x 24"
		1 ea	1/8" thick clear polycarbonate sheet, 12" x 24"
		1 ea	1/8" thick PVC Type 1 sheet 12" x 24"
		1 ea	0.5" thick x 2" wide 6061-T6 aluminum flat, 12" long
		1 ea	0.063" thick 5052-H32 aluminum sheet, 12" x 24"
		1 ea	0.5" diameter 6061-T6 aluminum round, 24" long
		2 ea	0.25" diameter AISI 1018 steel round, 24" long
		4 ea	Piano wire, 0.063" diameter, 12" long

<b>Wood Stock</b>	1 ea	7/16" to 1/2" thick 2' x 4' plywood, any grade
	1 ea	3/16" to 1/4" thick 2' x 4' plywood, any grade
	1 ea	3/4" or 1" rigid foam board insulation, 1' x 4'
	2 ea	1" x 4" (nominal) #2 whitewood, 2 ft long
	1 ea	1/4" dia. oak dowel, 3 ft long
	2 ea	3/4" schedule 40 PVC pipe, 5 ft long
<b>Pipes and Fittings</b>	2 ea	1" schedule 40 PVC pipe, 5 ft long
	1 ea	4" PVC solid pipe, SDR 35 or ASTM D2729, 3 ft long (without integral coupling)
	10 ea	3/4" PVC 90 degree elbow (slip)
	10 ea	3/4" PVC tee (slip)
	6 ea	1" PVC 90 degree elbow (slip)
	6 ea	1" PVC tee (slip)
	2 ea	1/2" metal EMT conduit, 5 ft long
	1 ea	PVC cement, 4 oz or 8 oz
<b>Hardware</b>	4 ea	2.5" x 5/8" steel ZN, corner angle bracket
	4 ea	2" x 3/8" steel ZN, flat angle bracket
	2 ea	2.5"H x 1.75"W x 0.055" narrow hinge w/removable pin
	1 ea	extension spring for heavy doors, 13/32"OD, 0.0625" wire diameter, steel
	1 ea	3/4" metal pipe hanger tape, 28 gauge, 10 ft long
	<b>Electrical</b>	12 ft
12 ft		18 gauge stranded copper wire, black insulation, single conductor



	12 ft	CAT3 24 gauge, 4 twisted pairs of conductor wire
	16 ea	snap-plug terminals (bullet connectors), insulated, male (optional*)
	16 ea	snap-plug terminals (socket for bullet connectors), insulated, female (optional*)
	20 ea	quick-disconnect terminal, insulated, female, ~1/8" wide (optional*)
	10 ea	quick-disconnect terminal, insulated, female, ~3/16" wide (optional*)
	4 ea	sub-mini snap action switch, SPDT, 0.1 A, Omron P/N SS-01GL13PT
	2 ea	rotary potentiometer, linear, 10K ohm, 300°, panel mount, 6mm (approx.) shaft
	2 ft	heat shrink tubing, 1/4" OD expanded, 2:1 ratio, polyolefin, black
	10 ea	11" long x 0.18" wide nylon cable tie
	20 ea	4" long x 0.1" wide nylon cable tie
<b>Tapes and Adhesives</b>	1 ea	vinyl electrical tape, 3/4" wide, 60 ft
	1 ea	friction tape, 3/4" wide, 60 ft
	1 ea	all purpose duct tape, 2" (or 1.88") wide, 50 to 60 yd, (color optional)
	1 ea	painter's tape, 1" (or 0.94") wide, 30 to 60 yd.
	1 ea	carpenter's wood glue, 4 oz
	1 ea	5 minute epoxy, 0.85 oz
<b>Threaded Fasteners</b>	1 ea	1/4"-20 threaded rod, 3 ft long, steel
	25 ea	1/4"-20 hex nut, steel
	25 ea	1/4" SAE flat washer, steel
	25 ea	1/4" medium split lock washer, steel
	6 ea	1/4-28 x 1" screw, nylon (mates with igus rod end)
	6 ea	#10-32 x 1" socket head screw, high strength (150 KSI min) steel**
	25 ea	#10-32 x 1-1/2" machine screws, steel, round head, phillips **
	25 ea	#10-32 machine screw nuts, steel

	25 ea	#10 flat washer, steel
	100 ea	#8-32 x 1-1/4" machine screw, steel, pan head, phillips **
	100 ea	#8-32 machine screw nuts, steel
	25 ea	#8 medium split lock washer, steel (optional*)
	100 ea	#8 flat washer, steel
	25 ea	#4-40 x 1" machine screws, round head, steel **
	25 ea	#4-40 machine screw nuts, steel
	10 ea	#2-56 x 1" machine screws, pan head, phillips, stainless **
	10 ea	#2-56 machine screw nuts, steel
	10 ea	#2 flat washer, steel
	10 ea	wood screw eyebolts, 0.192 wire dia x .97 shank x .75 thread x .27 id, steel
	100 ea	#8 x 1" sheet metal screw, steel, hex head
	100 ea	#6 x 1" wood screws, steel, flat head
	25 ea	#4 x 3/4" wood screw, steel, slotted drive, round head
<b>Miscellaneous</b>	5 ft	3/4" nylon sticky back hook and loop fastener
	1 ea	#18 twisted nylon or polypropylene seine twine, 225 to 250 ft long (color optional)
	3 ft	1/4" polypropylene covered shock cord (color optional)
	2 ft	3/8" thick, 1" wide, adhesive backed, gum rubber strip
	1 ea	bicycle inner tube (26" x 1.5" to 2.00")
	1 ea	60x65" universal brake cable with housing (white or black)
	25 ea	#10 Rubber Band (1/16" wide x 1-1/4" long)
	25 ea	#32 Rubber Band (1/8" wide x 3" long)
	100 ea	1 1/4" long paper clips, 0.033 dia wire (No. 1 Regular)
	1 ea	VEX motor mounting kit ( 4 mounts + screws)

**Approved Optional Items (provided by team) <sup>1</sup>**

Qty	Item Description
10 ea	wooden spring type clothes pins
2400 sq in	corrugated cardboard, 1/4" maximum thickness
2 ea	empty food/beverage PETE container with screw on cap/lid (2 liter max.) <sup>2</sup>
3 ea	wire coat hangers with or without plastic coating, 1/8" dia. max.
3 ea	solid core golf balls
1 ea	5 minute epoxy, 0.85 oz
3 ea	~10oz empty metal soup can with lid removed
24 lb	pennies (cannot be altered; bank wrappers allowed)
1 ea	8 oz. PVC primer
36 ea	craft "Popsicle" sticks (maximum dimensions; 4.75" long, 0.44" wide, 0.10" thick)
1 ea	metal paint grid for 5 gallon bucket
4 ea	CD or DVD disk (standard size: 120mm diameter x 1.2 mm thick)
25 ea	deck or drywall screws; 2-1/2" maximum length
25 ea	wire management clips/ties/wraps (can only be used on wiring)
2 ea	Team Custom Part <sup>3</sup>

**Notes:**

\* Teams may use these optional items even if they are not supplied by the hub.

\*\* Teams may substitute shorter screws of the same type and grade.

<sup>1</sup> These items can be used *in addition* to the items that are supplied by the hub.

<sup>2</sup> PET or PETE (polyethylene terephthalate) is identified by a number 1 recycling symbol.

<sup>3</sup> See *Team Custom Part Guide* for further explanation and examples.

## 2.3 Design and Programming Software Tools

BEST Robotics provides various design tools and programming software at no cost to participating BEST teams. This currently includes:

- Sketching software – 2D sketching
- Computer-Aided Design (CAD) software – 2D & 3D Solid Modeling
- Computer-Aided Manufacturing (CAM) software – 2-axis and 3-axis tooling
- Software Development (programming) and Simulation Environments
- Mathematics, Computational and Research software
- 3D Printer Driver software
- Technical Documentation Tools

Software access instructions are provided at Kickoff and should remain confidential. A password may be required to view these instructions and will be provided by the hub. There may be specific system requirements, internet access requirements, account creation requirements or other stipulations for team/team member use of the software. Unless otherwise indicated, all software and software licenses should only be used by BEST participants for the purpose of competing in the BEST program.

## Section 3 Game Specific Rules



### 3.3 Introduction

Beyond food, air, and water, it could be said that there is one commodity that is essential to enable our civilization. It surrounds us, we use it countless times day and night, yet we rarely think about it. Then a natural disaster takes it away from us, and it is one of the highest priorities for us to get back.

Electricity is generated in many ways and transported all over the world via a high voltage distribution network known as the power grid. Carefully managed supplies and loads make sure it is available at the flip of a switch, until it isn't. With over 200,000 miles of high-voltage transmission lines and over 5.5 million miles of local distribution lines, in just the U.S. alone, disruptions are inevitable. When those disruptions affect thousands of miles of grid, like they did with hurricane Maria in Puerto Rico in 2017, anything that can help get the grid back up faster is invaluable.

Our linemen have the most dangerous job in the world. Disaster areas are the most dangerous of all because of live high voltage wires that have fallen to the ground and the substantial debris and obstacles that exist after such an event. A new type of lineman is needed to repair the power grid. Working with robots, the new generation of linemen will act as pilots/drivers and interact with the robot by loading payloads and equipment to be installed on the grid.

BEST Robotics is looking for an all-purpose system to repair the electric grid when catastrophe happens. Maintenance and repair of the power grid is one of the more dangerous occupations, so your goal is to help mitigate this problem by designing a robotic system to repair aerial high voltage lines, residential lines and underground buried cables; to transport and replace line insulators and transformers; and to clear and remove ground debris such as trees and limbs. In addition, your robotic system may be tasked to go into the most dangerous areas where the ambient field levels are so high that the system must autonomously navigate to deliver equipment to the towers.

### 3.4 Objectives

Design and build a robot capable of working with a lineman to perform the following tasks in rebuilding the power grid:

- Clear debris from roadways and dispose of the debris safely.
- Re-attach power lines to transmission line towers and residential poles.
- Install residential transformer(s).
- Install substation transformer(s)

- Install electrical conduit in underground trenches.
- Transport transmission line insulators to linemen in the field.

### 3.5 Game Field

Figure 3.1 gives a bird's eye view of the playing field. The major portions of the field represent the components of a power grid as described in the sections that follow. Figure 3.1 shows the high voltage and residential power lines installed on the towers and poles as they were before the disaster. Unfortunately, that is not the state of the lines at the beginning of the game.

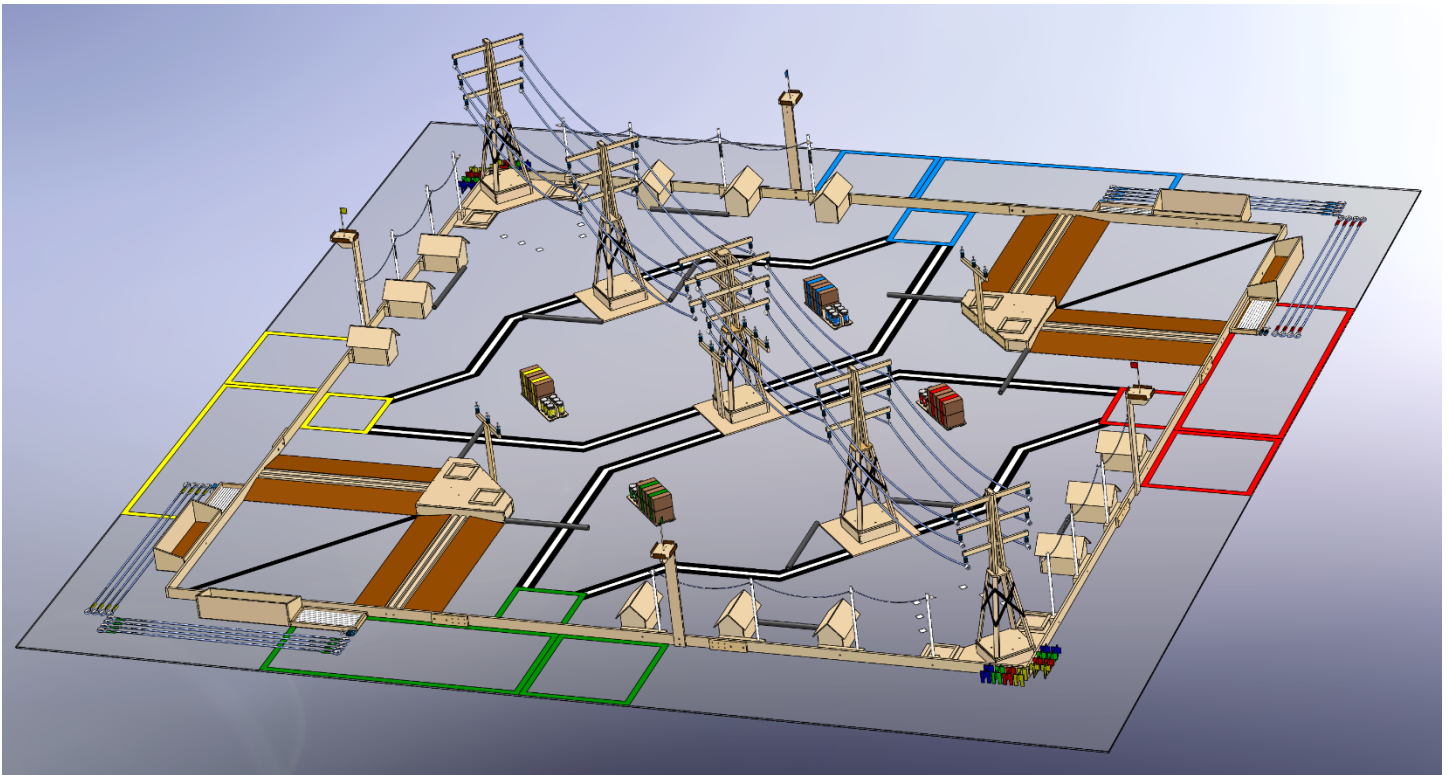

Figure 3.1 Game Field Overview

A power grid is a series of interconnected conductors that provide electrical power from a power generation plant to end users. For electrical power to travel great distances, it must be transmitted at very high voltage levels, then stepped down along the route as power is distributed to smaller areas and ultimately the end user's homes.

The four quadrants of the field represent four (4) major US power grids: Eastern, Western, Texas (ERCOT), Quebec. All four power grids are down due to a catastrophic event and must be restored to full service. Each power grid on the field is a series of transmission towers, distribution towers, residential poles and underground trenches that are connected to one another through power lines and electrical conduit. Power lines connecting the transmission towers have fallen and must be re-attached. Power lines between the transmission line tower and the distribution towers have been damaged and have no existing power lines connected to them at all; new lines must be attached between these towers. Power lines on the residential poles have also partially fallen and must be re-attached, like the transmission tower lines. Transformers have been damaged and must be replaced. Successfully restoring a power grid involves re-attaching the fallen transmission power lines, attaching distribution power lines, re-attaching the fallen residential power lines and installing new underground conduit lines in trenches that ultimately service the nearby homes.

Early responders have cleared roads for autonomous vehicles to deliver much needed supplies to the base of certain Transmission Line Towers. These roads are depicted as black/white stripes in Figure 3.2.

### 3.5.1 Field Layout

Figure 3.2 provides a top view of the field. The sections that follow provide more detailed descriptions of the field elements.

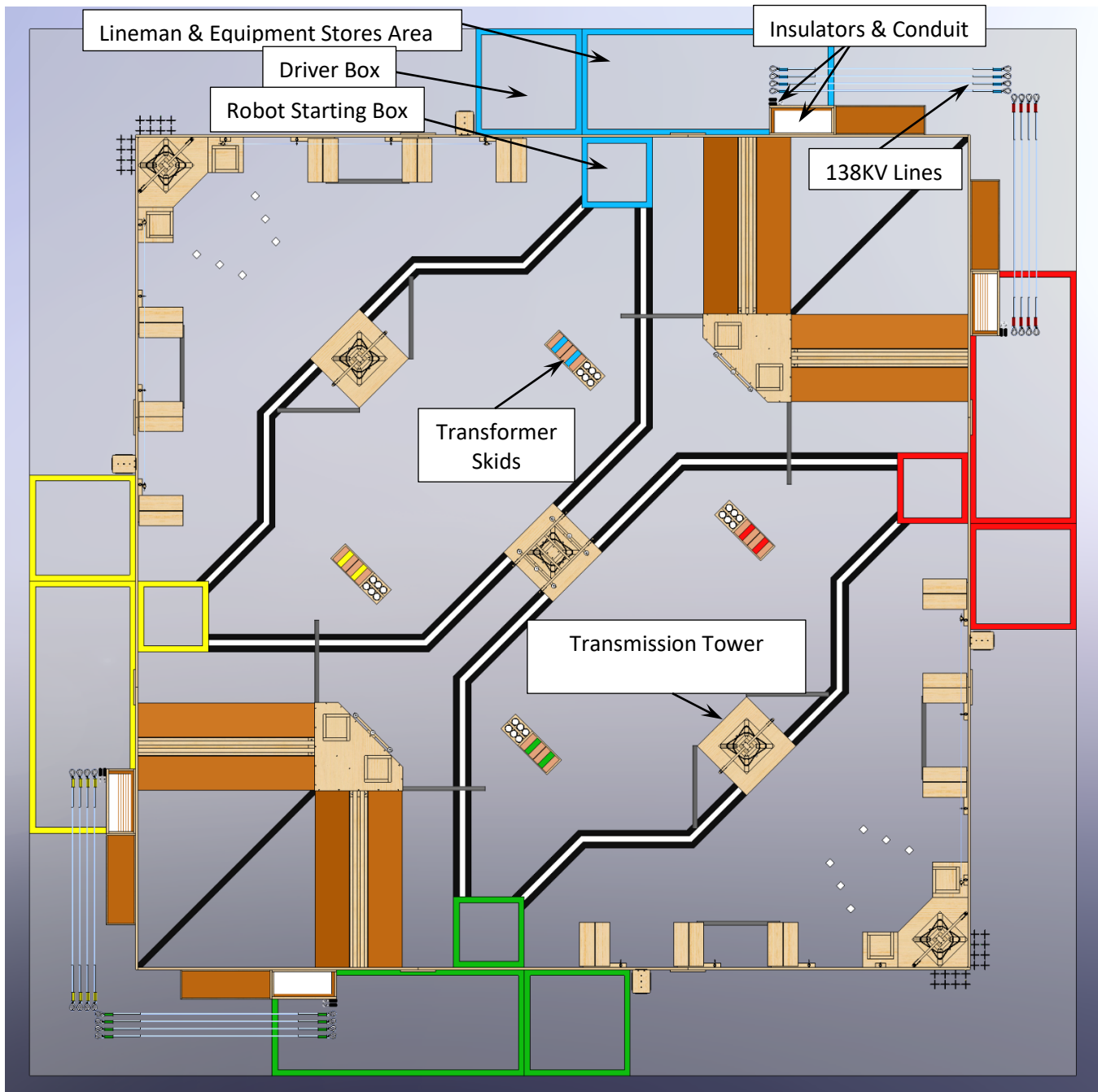

Figure 3.2 Field Top View

### 3.5.2 Power Grid Components

#### 3.5.2.1 Transmission Line Towers

Transmission line towers run down the center of the field from corner to corner. These towers carry two sets of three-phase 345KV high voltage power lines. Three power lines attach to insulators on each side of a transmission line tower.

The transmission line towers in the corners of the field have power lines that are pre-connected and have substation transformer receiving pads at their base (see Section 3.5.2.4). The heights from the ground to the tower insulator connection points for these Transmission Line Towers are approximately: Low connection – 35", Mid connection – 43", High connection – 51".

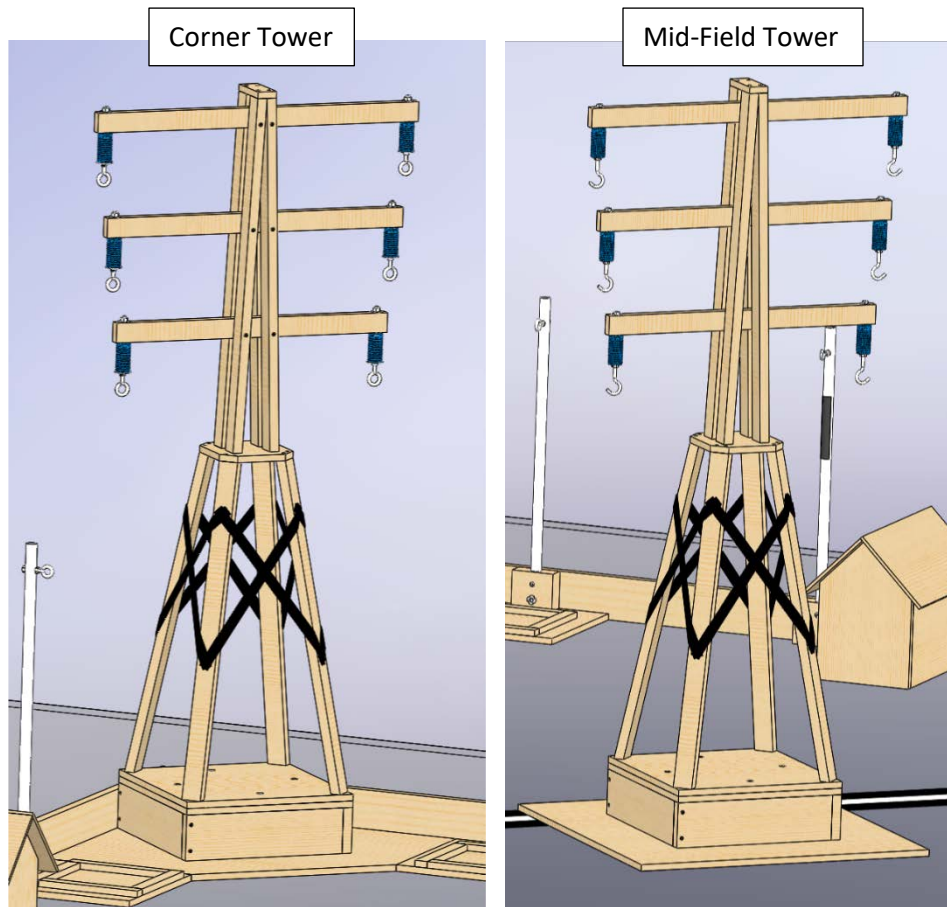

Figure 3.3 Transmission Line Towers

### 3.5.2.2 Transmission Line Transfer Tower

A Transmission Line Transfer Tower (Figure 3.4) is located at the center of the field. This tower is like the other Transmission Line Towers except that it provides additional connection points for six 138KV distribution power lines, three servicing each half of the field.

The heights from the ground to the tower insulator connection points for the 345KV power lines are approximately: Low connection – 34", Mid connection – 43", High connection – 51".

The height from the ground to all three tower insulator connection points for the 138KV power lines is approximately 26-3/4".



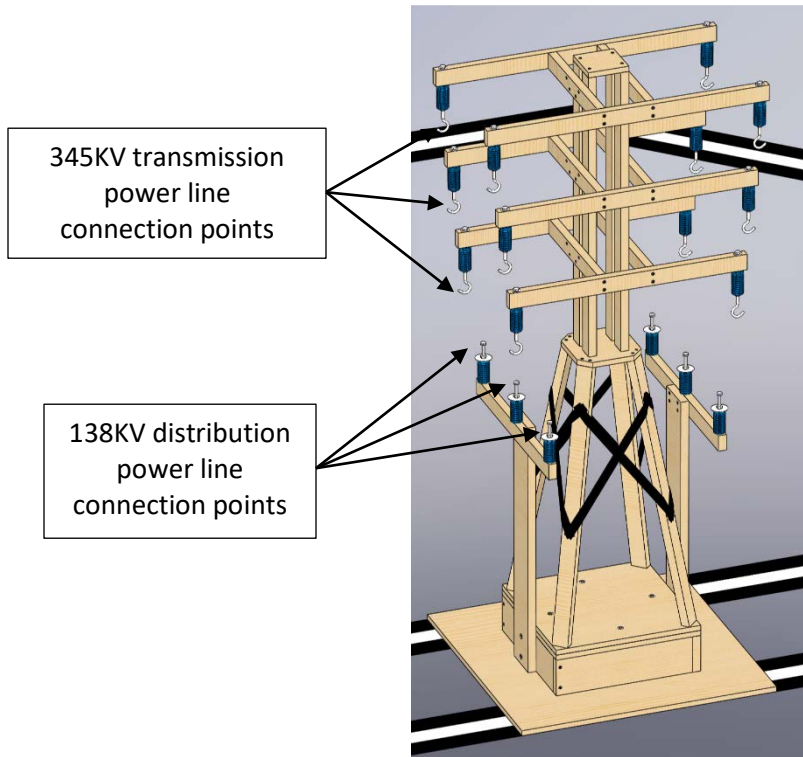

Figure 3.4 (Center) Transmission Line Transfer Tower

### 3.5.2.3 Distribution Line Towers

There are 2 distribution line towers that distribute 138KV 3-phase power lines from the center Transmission Line Transfer Tower to the Conduit Trenches on opposite corners of the field. There are receiving pads for two substation transformers at the base of each distribution line tower.

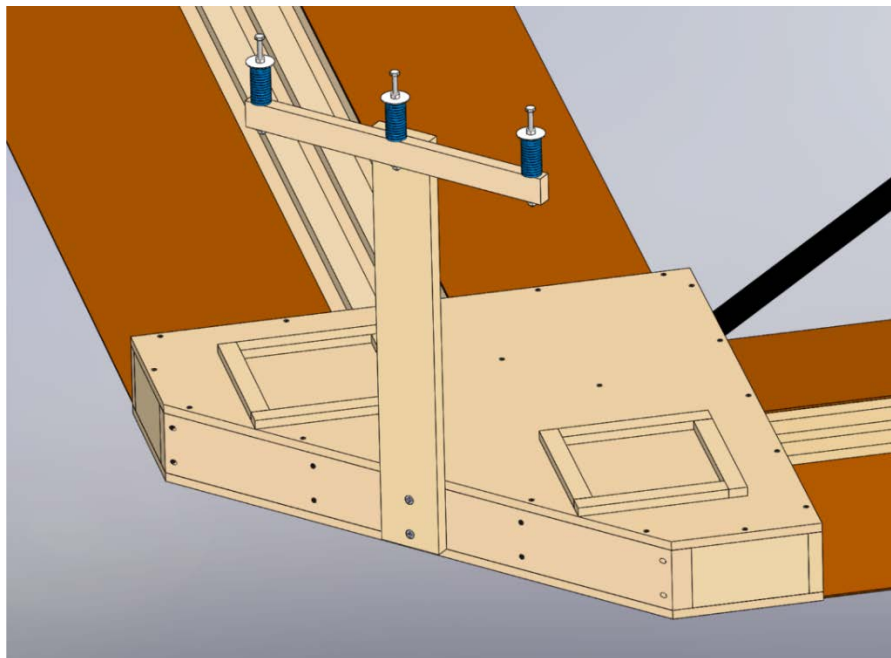

Figure 3.5 Distribution Line Tower

### 3.5.2.4 Power Substations

Power Substations are where high voltage power is stepped down (or converted) to a lower voltage through transformers for distribution to a smaller geographic area. As shown in Figure 3.6 and Figure 3.7, Power Substations exist at the base of two of the Transmission Line Towers and at the base of the two Distribution Line Towers. Each Power Substation contains two receiving pads for Substation Transformers.

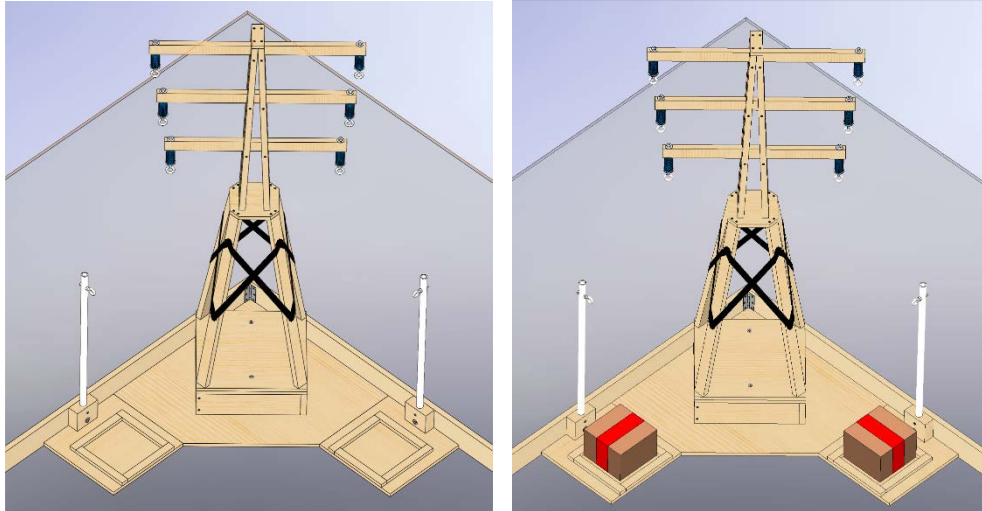

Figure 3.6 Transmission Line Tower with Substation Transformer Pads

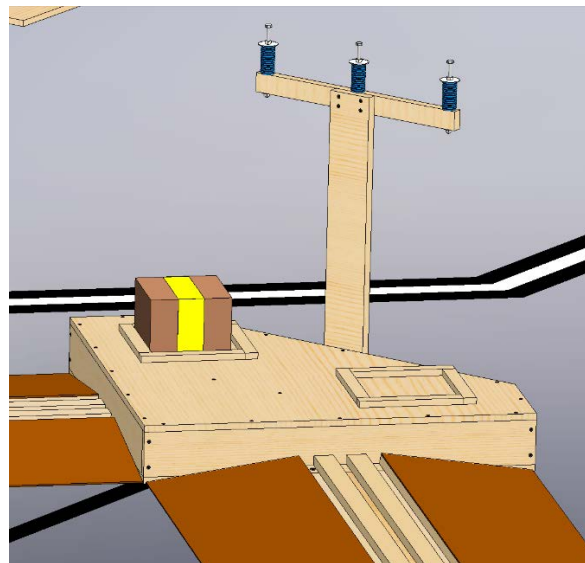

Figure 3.7 Distribution Line Tower with Substation Transformer Pads

### 3.5.2.5 Conduit Trenches

Conduit trenches are ~1 3/4" raised platforms having approximately 8-degree ramps on either side and 3 open trenches along the length of the assembly. Each trench is 3/4" wide x 3/4" deep x 60" long. 13KV conduit piping (19 1/2" in length) is laid in the trenches to make connection from the Distribution Line Towers to the residential homes. Each trench will accept up to three conduit pipes. The conduit trench is owned by the team whose Robot Starting box is the closest. This may be to the left or the right of the trench, depending on the field quadrant. Trenches are labeled A, B, C from left to right viewing from the outside of the field.

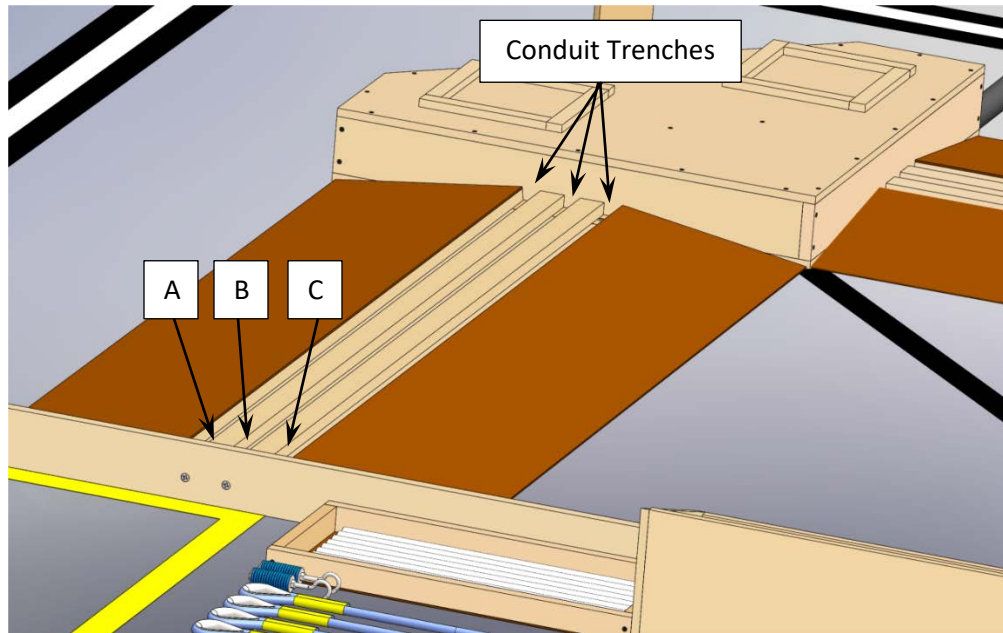

Figure 3.8 Conduit Trenches and Ramps

### 3.5.2.6 Residential Homes and Residential Power Pole

There are three residential homes in each quadrant of the field that are serviced by a 4KV single phase power line carried along the residential power poles and a transformer on each pole. Each pole supports a single residential transformer to step down voltage to 120V for the homes. Figure 3.9 shows the arrangement of one house with its power pole.

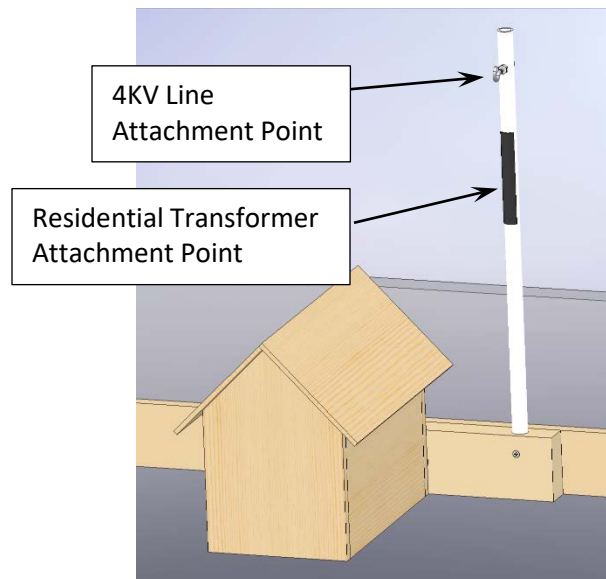

Figure 3.9 Residential Home with Power Pole.

The residential power lines are owned by the team assigned to the quadrant and may only be installed by the team assigned to the quadrant. Each quadrant contains one residential power line that is pre-attached to the power pole near the corner substation for that quadrant and can only be connected to the remaining residential poles in that quadrant. The connection point for the residential line is approximately 23-1/2" above the field surface.

Residential transformers, however, may be installed on ANY residential power poles in ANY quadrant. Figure 3.10 shows a power pole with a residential transformer installed. The base of the hook and loop attachment point for the transformer is approximately 15" from the field surface.

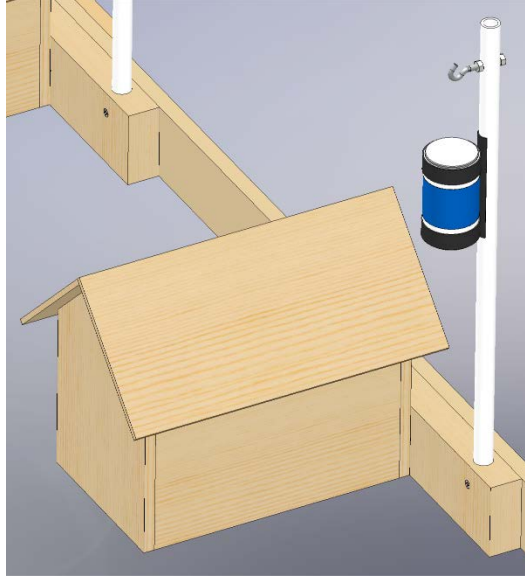

Figure 3.10 Residential Power Pole with Installed Transformer

### 3.5.3 Transformer Skids

Four (4) skids of new transformers have been dropped off by the local power companies; one skid in each quadrant. Each skid contains color-coded transformers that are owned by the team assigned to the quadrant of corresponding color. Transformers are to be removed from the skid and installed on any of the available substation receiving pads. Residential transformers are to be removed from the skid and installed on any available residential power poles.

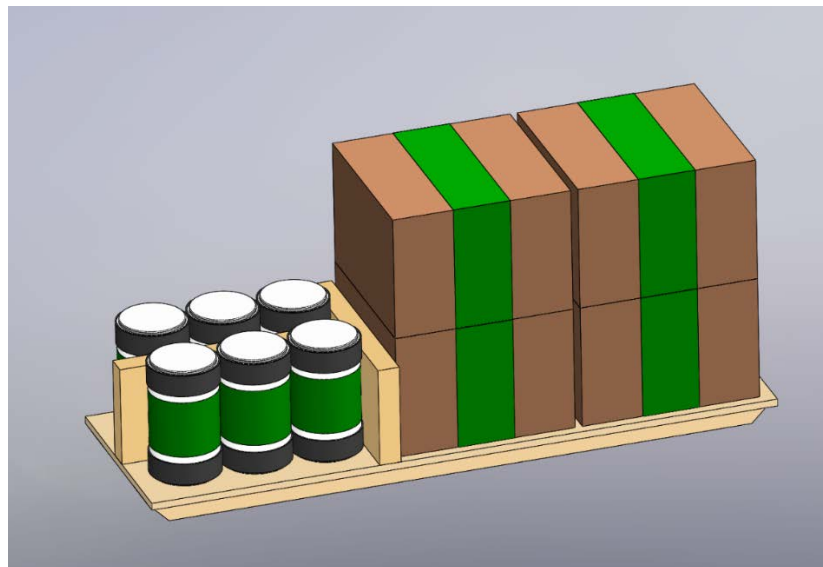

Figure 3.11 Transformer Skid

### 3.5.4 Scattered Debris

Debris such as fallen tree trunks and tree limbs are scattered throughout the field. Such debris may block roads or other areas as shown in Figure 3.12. The debris may need to be moved or cleared from the field to gain access to other scoring opportunities. See section 3.6.4 for details on the size and makeup of the debris. The debris is in the same locations in each field quadrant.

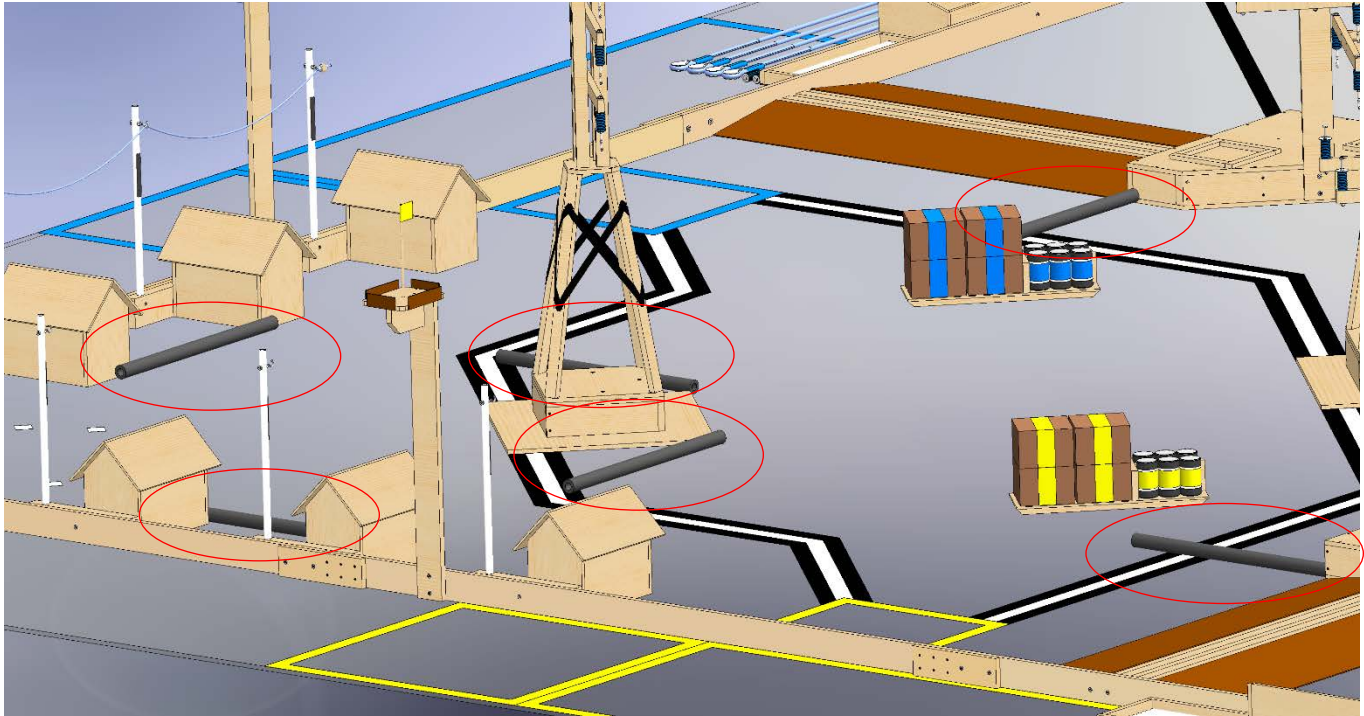

Figure 3.12 Debris Locations Within a Quadrant

### 3.5.5 Debris Disposal Staging Area

The Debris Disposal Staging Area is a triangular shaped area within each field quadrant that is a safe location for storing debris cleared from the field. This area is a staging area for debris prior to being loaded into the dumpster for eventual disposal. The staging area is defined by the inner edge of the conduit ramp, inner edge of the field boundary, and inner edge of the tape line (i.e., the light colored triangular section shown in Figure 3.13).

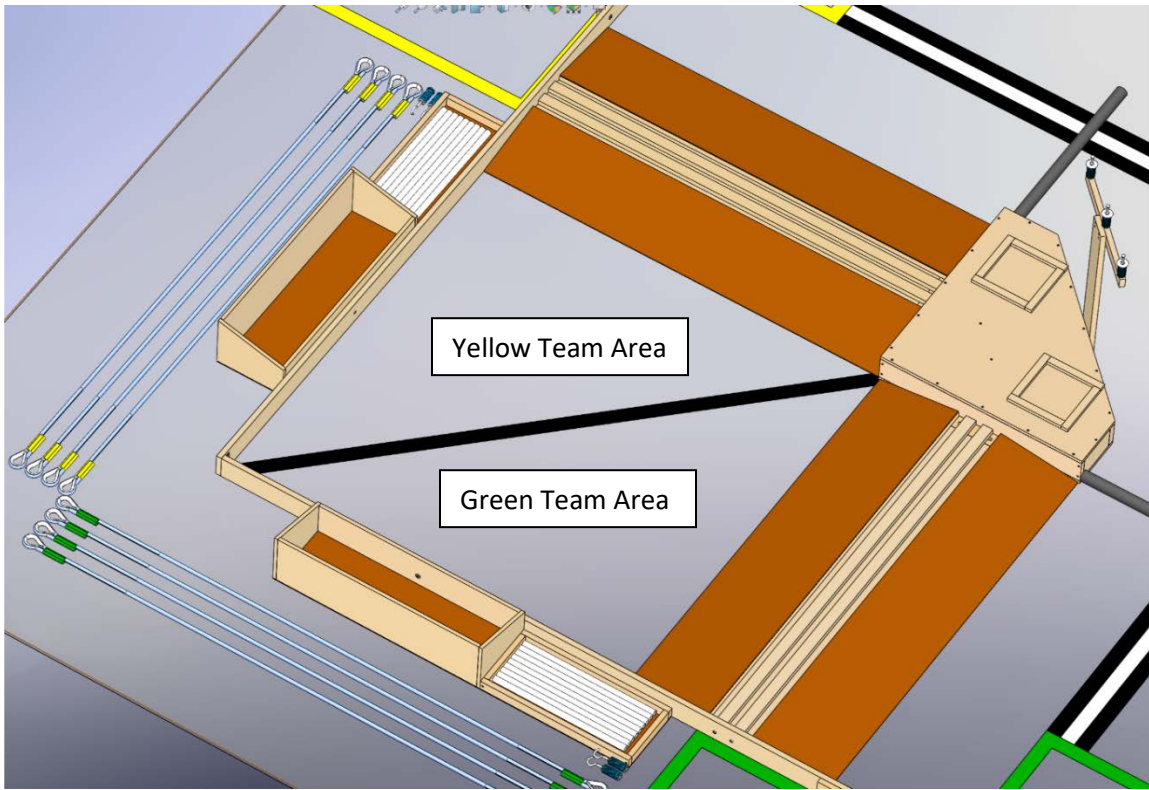

Figure 3.13 Debris Disposal Staging Areas

### 3.5.6 Dumpster

To aid in the cleanup effort, a 31" L x 10" W x 8" H dumpster is located just outside of the Debris Disposal Staging Area of each field quadrant and is attached to the field border as shown in Figure 3.14. Once debris is placed in the container, it cannot be removed.

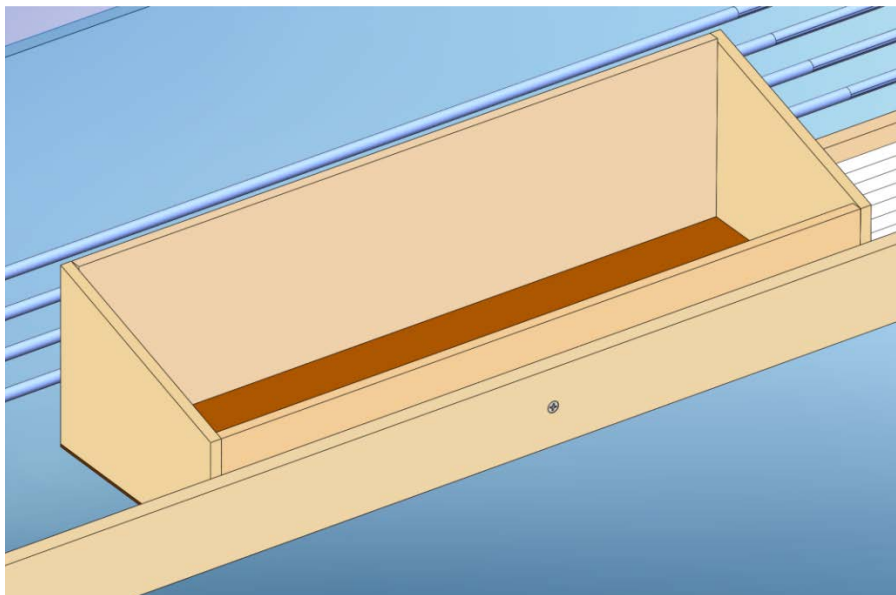

Figure 3.14 Dumpster

### 3.5.7 Autonomous Vehicle Roadways

There are 8 roadways (2 in each quadrant) to the transmission line towers. The roadways have been previously cleared by first responders but may still be cluttered with debris. The roadways are marked as a 2" wide white line, surrounded by a 2" wide black border on either side, as shown in Figure 3.2. The roadways can be useful to autonomous vehicle delivery of tower components.

### 3.5.8 Robot Starting Box

The Robot Starting Box is located to the side of the underground conduit trenches in a quadrant. The robot starting box will be either to the left or to the right of the underground conduit trenches, depending on the quadrant. The starting box is designated by tape and measures 24" x 24" from the outside edge of the tape line.

- a. The robot must remain fully inside the Robot Starting Box and in the 24" x 24" x 24" starting configuration until the match begins.
- b. A colored flag (robot identifier flag) will be installed on each robot prior to the match designating its quadrant and team ownership.

### 3.5.9 Driver's Box



The Drivers Box is a 36" x 36" square area located outside of the field boundary and adjacent to the Residential Home nearest to the mid-point of the field boundary.

### 3.5.10 Lineman & Equipment Stores Area

A 60" x 36" Equipment Stores area exists outside of the field boundary and adjacent to the Robot Starting Box and Driver's Box. The Lineman (spotter) will operate in this area and may transfer equipment from this area to/from the robot or Robot Starting Box whenever the base of the robot identifier flag is inside the Robot Starting Box.

## 3.6 Game Pieces

### 3.6.1 Power Lines

Power Line	Description	Image
345KV Transmission Line	<p>~186" long, 1/2" diameter Poly rope, braided</p> <p>One end pre-connected to corner tower using a screw eye attachment point.</p> <p>3/4" PVC cap on both ends.</p> <p>Lower line on tower is unique color from others and its end cap is color-coded by team. See Drawings Package.</p>	 <p>Showing one end only.</p>
138KV Distribution Line	<p>~80" long, 1/2" diameter Poly rope, braided</p> <p>Wire thimble at both ends with colored shrink tube to hold rope in place tightly.</p>	

		Showing one end only.
4KV Residential Line	~91" long, 1/4" diameter Poly rope, braided  One end pre-connected to pole nearest to the corner using a screw eye attachment point. 1" diameter wooden ball on both ends.	 <p>Showing one end only.</p>

### 3.6.2 Underground Conduit

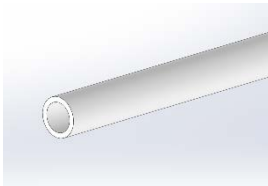
Item	Description	Image
13KV Electrical Conduit Pipe	19-1/2" length of 1/2" S40 PVC pipe. ~4-1/8 oz. weight.	

### 3.6.3 Transformers

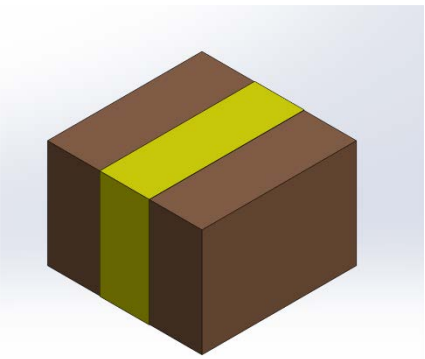
Item	Description	Image
Substation Transformer	6" x 6" x 4" cardboard box, closed. Taped shut with colored tape. ~4-1/2 oz weight.	

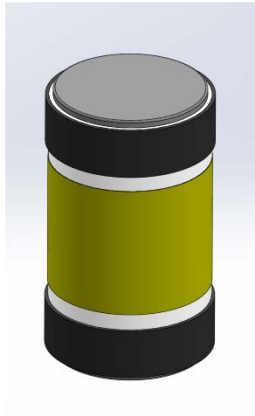

<p>Residential Transformer</p>	<p>4" long, 2" diameter S40 PVC Pipe, with end cap inserts closing both ends.          ~4-3/4 oz weight.</p> <p>2 bands of Velcro on ends, 2" colored tape around the center.</p>	
--------------------------------	---	---

### 3.6.4 Debris

Item	Description	Image
<p>Ground Debris</p>	<p>28" long, 3/4" Pipe Insulation, ~2" diameter.          ~1/2 oz weight.</p>	

### 3.6.5 Autonomous Delivery Item

Item	Description	Image
<p>Spare Tower Insulator</p>	<p>Custom part.          approximately 5" long, 1" diameter.          ~2-1/8 oz weight.</p>	

### 3.6.6 Quantity and Starting Locations

Game Piece	Qty Owned/Assigned Per Team @ Match Start	Total Scoring Opportunities Per Team	Total Per Field Scoring Locations	Match Starting Location
345KV Power Lines (Transmission) LOWER	1	2*	8	Attached to corner Transmission Line Towers. A portion of the line is lying on the floor, extending from the corner tower. See drawings for placement.
345KV Power Lines (Transmission) MIDDLE	0	8**	8	Attached to corner Transmission Line Towers. A portion of the line is lying on the floor, extending from the corner tower. See drawings for placement.
345KV Power Lines (Transmission) UPPER	0	8**	8	Attached to corner Transmission Line Towers. A portion of the line is lying on the floor between corner tower, extending from the corner tower. See drawings for placement.
138KV Power Lines (Distribution)	4	4	6	Equipment Stores Area
4KV Power Lines (Residential)	1	3***	3	Attached on residential power poles nearest corner Transmission Line Towers. Lying across the tops of two residential homes and not touching the ground.
13KV Conduit Pipes	9	9	36	Equipment Stores Area
Residential Transformer	6	6	12	Transformer Skid
Substation Transformer	4	4	8	Transformer Skid
Spare Tower Insulator	2	2	8	Equipment Stores Area
Ground Debris	0	12	12	See Field Drawings for exact starting locations <ul style="list-style-type: none"> <li>• One touching transmission tower and the two-turn roadway.</li> <li>• One butted against two homes.</li> <li>• One lying perpendicular across the one-turn roadway.</li> </ul>

\* 2 scoring opportunities (segments) per team; 1 assigned line x 2 segments

\*\* 8 scoring opportunities (segments) per team; 1 lines x 2 segments each x 4 quadrants

\*\*\* 3 scoring opportunities (segments) per team.

## 3.7 Grid Construction Rules

### 3.7.1 Robot Identifier Flag

For each match, a team's robot will be associated with their field starting position via a colored Robot Identifier Flag. The flag assembly consists of a 11-3/4 long piece of 1/4-inch dowel with a 2x2 inch colored flag made from gaffers tape.

- The Robot Identifier Flag will be located on the field mounted on the hands-free transmitter shelf.
- The flag must be affixed to the robot vertically, within 12 inches of the Cortex microcontroller.
- The flag does not have to fit within the 24" x 24" x 24" robot starting configuration.
- The flag cannot be used as a functional part of the robot (robot must function the same with the flag removed).
- The flag must be returned to the starting position on the hands-free transmitter shelf after the completion of the match.

### 3.7.2 Team Ownership

Teams "own" certain game pieces and areas of the field during the match and may become the "owner" of other game pieces as the match progresses.

- A team owns any game piece that is color-coded to match the quadrant the team is assigned to during the match (residential transformers, substation transformers, 138KV distribution lines, 4K residential line, one of the lower 345KV transmission lines).
- A team owns certain field areas (trenches, dumpster, debris disposal staging area) within their assigned quadrant for the match. Items scored in these areas will add to the score of the team that owns the area regardless of how they arrived there.
- A team can assume "ownership" of the unassigned 345KV transmission lines by making a successful connection or installation of the line. Grasping a line does not constitute ownership. Once a line is "owned" by a team, it does not change ownership.

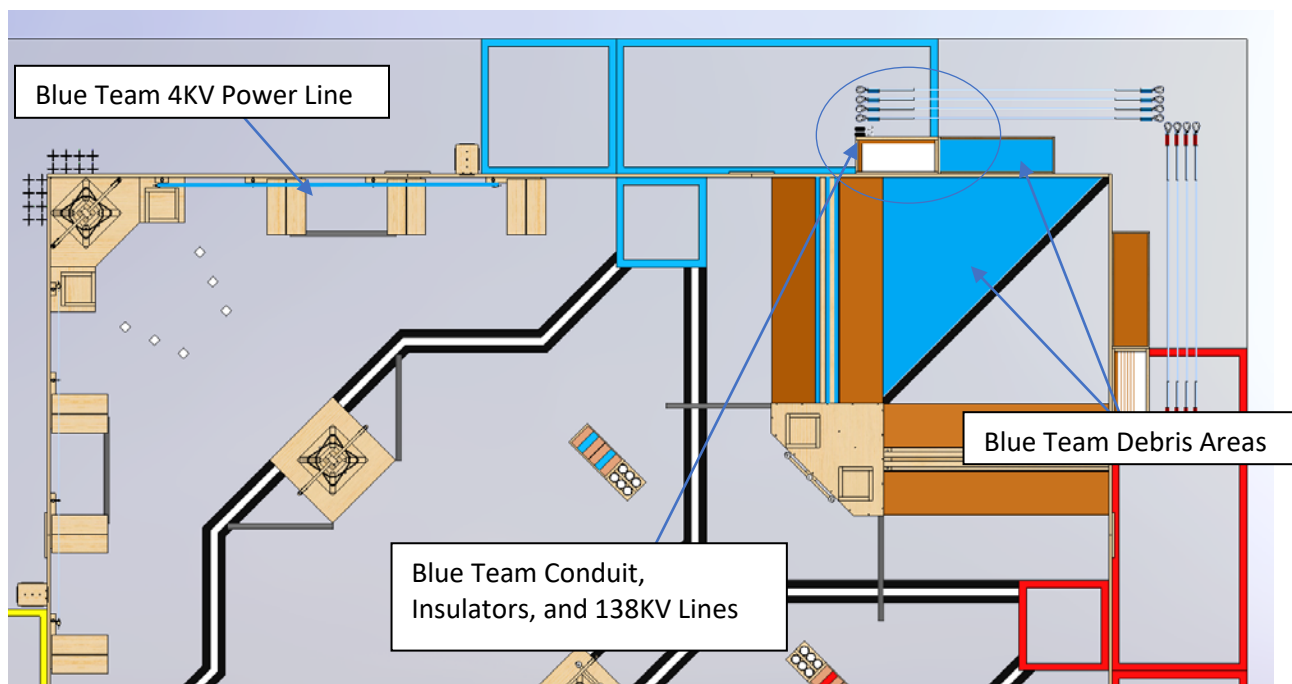

Figure 3.15 Example Team Ownership (Blue Team)

### 3.7.3 Remove Ground Debris

- a. There are twelve (12) total debris items that have been scattered around the field.
- b. There are three (3) debris items within each quadrant at the beginning of a match.
  - o One (1) debris item in each quadrant lies in contact with a corner of one (1) of the transmission towers and the edge of the two-turn roadway.
  - o One (1) debris item in each quadrant lies perpendicular to and over the one-turn roadway and in contact with the distribution tower base.
  - o One (1) debris item in each quadrant butts against the two residential homes nearest the corner of the field.
  - o See the Field Drawings for the EXACT starting locations for the debris.
- c. The robot may remove debris anywhere on the field and move it into a debris disposal staging area or place it into the dumpster adjacent to a debris disposal staging area.
- d. Points are awarded for debris [inside](#) the boundaries of a debris disposal staging area owned by the team at the end of the match. Refer to Figure 3.13 and Section 3.10 for clarity.
- e. Points are awarded for debris that is fully inside the boundaries of a dumpster owned by the team at the end of the match. The boundaries of a dumpster are defined by the infinite vertical planes created by the inside walls of the dumpster. Refer to Section 3.10 for clarity.
- f. Robots may manipulate any debris on field that is not contained within a dumpster. Debris is not considered removed and ready for transport until it is in the dumpster. Debris within a team's Debris Disposal Staging Area is considered cleared but is still accessible by all teams.

### 3.7.4 Attaching 345KV Transmission Lines

One end of each 345KV high voltage power line is attached to the corner transmission line towers. The corner transmission tower has six total power lines, three on each side (i.e., three per quadrant).

- a. The lower power line is pre-assigned (color coded by team) and can only be connected by the team/robot assigned to the quadrant.
- b. The two upper power lines are not assigned and can be connected by ANY team/robot.
- c. When a robot makes the first connection of an unassigned line to a tower insulator, the line becomes "owned" by the team/robot that made the connection.
- d. The referee will tag the line ownership through a colored flag on the corner tower cross beam near the line insulator matching the colored identifier flag on the robot.
- e. Once a line is "owned" by a team, it does not change ownership.
- f. Points are awarded by connecting power line segments on the same side of tower at the same tower level (low, mid, high); where a segment is a line supported by the insulators of two towers and the line is not grounded between the two towers (i.e., not touching the ground, uninsulated part of a tower, or robot - no path to ground).
- g. Points are awarded for all 345KV power line segments properly connected by a team at the end of the match. Contact between 345KV power lines does not affect the score.
- h. If a line falls after a successful connection is made to the tower, ownership of the line does not change; but points are only awarded for completed segments at the end of the match.

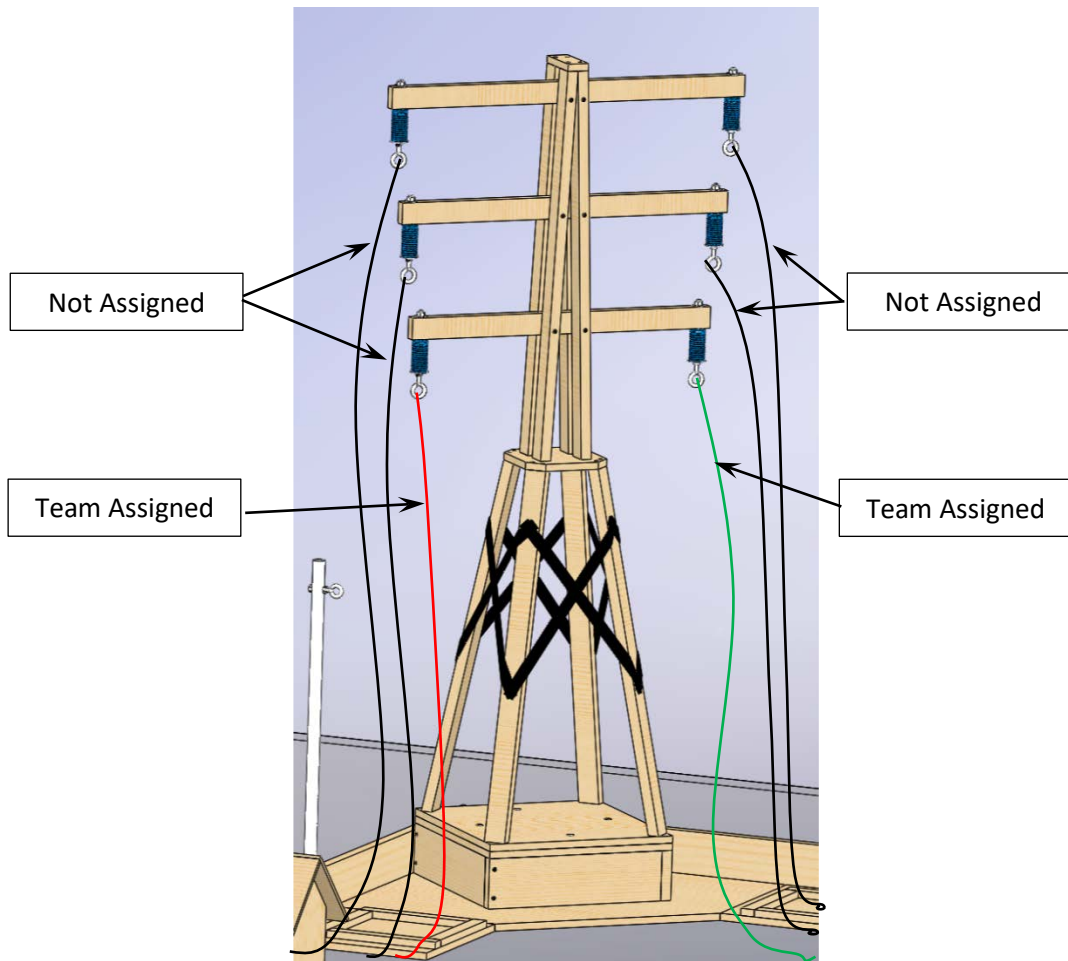

Figure 3.16 Transmission Line Tower with Permanently Attached Power Lines

### 3.7.5 Attaching 138KV Distribution Power Lines

- Any robot may connect 138KV power lines on the six available tower insulator posts between the center Transmission Line Transfer Tower and either of the two Distribution Line Towers.
- Only one line may be connected to any tower insulator; only the first line connected to an insulator will score.
- 138KV power lines are color coded by team to designate ownership and are available in each team's Equipment Stores Area at the beginning of the match.
- Points are awarded for connecting one or both ends of the 138KV power line to the towers. "Connected" means that a line thimble is supported by a tower insulator post. Reference diagrams in Section 3.10.
- Connecting both ends of a 138KV power line results in a power line segment. A 138KV power line segment must connect the corresponding insulators on the center Transmission Line Transfer Tower and a Distribution Line Tower (phase A, B, or C) in order to score. A connection from  $A \leftrightarrow B$ ,  $A \leftrightarrow C$ , or  $B \leftrightarrow C$  will not earn points for the second connection and will not count as a correctly connected power line segment. Note that 138KV power lines connected between two towers may droop significantly.
- Contact between 138KV power lines does not affect the score.

A

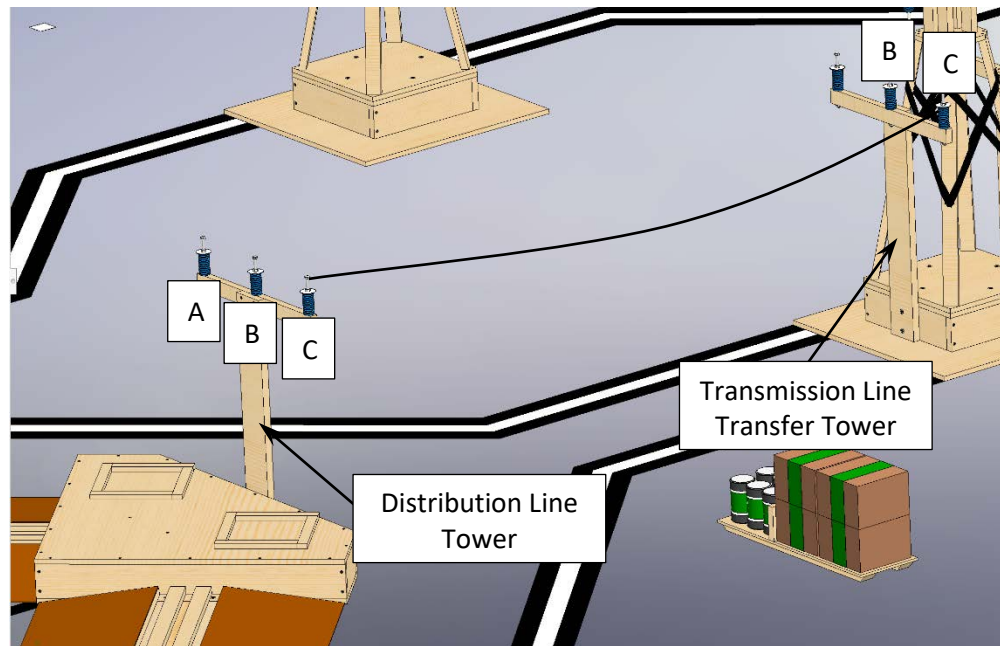

Figure 3.17 Valid 138KV Power Line Connections

### 3.7.6 Attaching 4KV Residential Power Line

- The 4KV residential power line must be connected by the robot.
- There is a single 4KV residential power line available within each power grid (quadrant), color coded by team.
- One end of the 4KV residential power line is pre-attached to the pole closest to the substation transformer pads (in each corner of the field) at the beginning of the match.
- The residential power line may only be connected to the residential power poles within the assigned quadrant.
- There can be only one power line connection per residential power pole.
- The residential power line is considered connected when the power line is fully resting on the insulator hook.
- Points are awarded for every connected residential power line segment, where a segment is a power line supported by the insulators of two poles and not grounded (i.e., not touching the ground or houses, or any other part of a pole between the two poles - no path to ground between the poles).
- Points are awarded for the number of residential line segments that are connected at the end of the match.

### 3.7.7 Install Residential Transformers

- Residential transformers are color-coded indicating team ownership.
- Residential transformers must be installed by the robot.
- Six (6) Residential transformers exist on each team's Transformer Skid at the beginning of the match.
- Residential transformers may be installed on ANY residential power pole on the field.
- Only one (1) residential transformer can be installed on a single residential power pole.
- Points are awarded at the end of the match for transformers that are installed on residential power poles.
- A residential transformer that remains affixed to any Velcro on the residential pole at the end of the match will be considered "installed".

### 3.7.8 Install Substation Transformers

- Substation transformers are color-coded indicating team ownership.

- b. Substation transformers must be installed by the robot.
- c. Four (4) Substation transformers exist on each team's Transformer Skid at the beginning of the match.
- d. Substation transformers may be installed at ANY Power Substation, located at the base of the two corner Transmission Line Towers and at the base of the two Distribution Line Towers.
- e. Up to two (2) Substation transformers can be installed at a Power Substation (i.e., one on each substation transformer pad).
- f. Points are awarded at the end of the match for transformers that are installed on Power Substation transformer pads.
- g. A substation transformer is considered "installed" when either 6x6 side is touching the base of the tower flush and the transformer sits within the boundaries of the receiving pad. Refer to example in Section 3.10.

### 3.7.9 Installing 13KV Conduit Pipe

10. Each team is provided with nine (9) conduit pipes in their Equipment Stores Area.
11. Conduit pipes will score based on where they are located at the end of the match.
12. Conduit pipes must be installed by the robot.
13. The Lineman may load pipe(s) onto the robot at any time during the match (see Section 3.7.12).
14. The base of the robot identifier flag must be outside of the Robot Starting Box before the robot can install pipe in a trench.
15. Both ends of the conduit pipe must be touching the bottom of the trench for the pipe to be considered "installed".
16. A conduit trench is owned by the team whose Robot Starting box is the closest. This may be to the left or the right of the trench, depending on the field quadrant.
17. Points are awarded to the team owning the trench for each pipe installed within a trench.

### 3.7.10 Autonomous (Driverless) Equipment Delivery

Some transmission line towers need spare tower insulators for on-going repair/replacement operations. These unique destinations may still contain live high voltage power lines thus making the delivery too dangerous for normal work trucks. Your robots are needed to make these deliveries but since the entire grid is down, we cannot count on consistent communications from remote drivers. The robots will therefore need to navigate autonomously to deliver their payload into these areas using their own on-board sensors to guide them. There are roadways to the towers that have been previously cleared by first responders but may still be cluttered with debris. Robots may choose to use these roads to guide them to the delivery destination or may find their way to the delivery destination through other routes on their own.

#### Task Description

11. The equipment payload (a spare tower insulator) must be transported by the robot from the robot start box to either of two destinations fully autonomously (no driver joystick control).
12. There are two team-owned spare tower insulators in the Equipment Stores Area at the beginning of the match.
13. There are two possible transmission tower destinations per quadrant (see Figure 3.2).
14. Only one payload may be transported during each autonomous delivery.
15. Equipment payloads can be deposited at either destination. Each destination can receive up to two payloads.
16. Transporting involves carrying, pushing or pulling the payload from the robot start box to the destination.
17. Two (2) color contrasting "roadways" (2" white line surrounded by 2" black line on either side) are marked on the field between the robot start box and the possible destinations at the two transmission towers. Following these paths is not required but they are available as an aid to the robot during the autonomous period.

#### Procedure

18. The autonomous delivery can be attempted at any time during the match. The driver must notify the referee of the attempt before initiating any autonomous delivery operation.
19. An autonomous setup period will begin when the base of the robot identifier flag is completely [inside](#) the robot start box and the driver places the joystick on the hands-free platform within the driver's box and is no longer touching it.
20. During the autonomous setup period, the Lineman may orient the robot within the start box prior to the driver initiating the autonomous delivery operation so long as the base of the robot identifier flag remains within the robot start box. NOTE: There may be resetting and manipulation only of existing parts on robot. Tools are not allowed.
21. During the autonomous setup period, the Lineman may load the equipment payload onto the robot.
22. The lineman may not be touching the robot or any part of the field when the autonomous delivery operation is initiated by the driver.
23. The driver will initiate autonomous delivery operation by pressing any combination of buttons on the joystick (without lifting it from the hands-free platform).
24. The autonomous delivery period ends when the driver touches or lifts the joystick from the hands-free platform.

### Evaluation

- o. To earn points, the equipment payload must be unloaded (no longer touching the robot) before the autonomous delivery period ends and must break the infinite vertical plane defined by the outer edges of the tower platform.
- p. At the end of the autonomous delivery period, the referee will verify that the equipment payload is in the correct position at the transmission line tower platform and will score the transfer as successful if so. The payload is only required to be in position at the end of the autonomous delivery period; once scored by the referee (by a thumbs up or thumbs down), the payload may move.
- q. At the end of the autonomous delivery period, if the payload is not in a scoring position (unsuccessful delivery) and is within reach of the robot it may be retrieved by the robot under manual driver control and returned to the robot start box for another autonomous delivery attempt.
- r. Since a robot is allowed to retrieve the payload on a failed attempt and success is subject to verification by the referee, it is imperative that the driver wait for the referee's signal (thumbs up or thumbs down) confirming or denying a successful delivery before continuing manual driver control or risk having the delivery denied.

### 3.7.11 Interaction with Other Robots, the Field and Game Pieces

The spirit and intent of the tasks is for teams to construct robots capable of completing the assigned objectives in an environment where multiple robots have access to limited game pieces and grid construction opportunities. Some game pieces are "owned" by a specific team (i.e., color-coded) or become "owned" by a team during reconstruction of the grid (see section 3.7.1). The goal is to reconstruct the failed power grid; manipulating game pieces that are already in scoring position is not allowed.

6. Robots may not take game pieces in the grasp of, or contained on, another robot.
7. Robots may not remove or dislodge power lines "owned" by another team.
8. Robots may not control any game pieces "owned" by another team. Pushing a game pieces does not demonstrate control. Pulling, dragging, lifting, or carrying a game piece demonstrates control.
9. Robots may not remove or dislodge any game piece in a scoring position placed by another team.
10. Game pieces may not be placed into a scoring position while the base of the robot identifier flag is [inside](#) the robot start box.
11. Tower insulators only accept a single connection. Once a connection is made, robots may not make additional connections to the same insulator.



12. Intentional contact between robots for the sole purpose of obstructing autonomous deliveries will result in disqualification of the obstructing robot. Contact between robots will occur; it is expected to be incidental, not intentional.
13. Robots may touch, push, or move any transformer skid on the field.
14. Robots may manipulate any debris on the field that is not contained within a dumpster. Debris is not considered “owned” until it is in the dumpster. Debris within a team’s Debris Disposal Staging Area is still accessible by all teams.
15. If a robot and power line(s) become entangled, the referee will have discretion to untangle them if there is possible damage to the field. There will be no action taken if power lines become entangled on the field.
16. Any violation of the interaction rules will result in a disqualification for the current match.

### 3.7.12 Driver and Lineman Rules

The following rules apply to Driver and Lineman actions during the match.

- a. The Lineman may touch the field inside the Robot Start Box during interactions with the robot (loading of game pieces or during the autonomous setup period).
- b. The Lineman may reposition the robot and may manipulate any existing components on the robot during the autonomous setup period. Refer to section 3.7.10 j.
- c. Game pieces that touch the floor outside of the field boundary and Equipment Stores Area are considered out of play and will be removed by the referee.
- d. Game pieces that are placed into the robot start box or onto the robot by the Lineman do not need to be completely inside the robot start box when driver control is resumed or the autonomous delivery starts (i.e., when the joystick is touched by driver).

Any violation of the following rules (e through g) will result in a **disqualification** for the current match.

- e. The Driver may not touch any part of the field, any game piece, or the robot during the match.
- f. The Lineman may not touch any game piece “owned” by another team.
- g. Only game pieces that started the match in the Equipment Stores Area may reside inside the Equipment Stores Area or Robot Start Box during the match.

Any violation of the following rules (h through k) will result in a **20 second penalty** during the current match.

- h. The Driver must keep his/her feet within the Driver’s Box during the match.
- i. The Lineman must keep his/her feet within the Equipment Stores Area during the match.
25. The Lineman may not touch the ground outside of the Equipment stores Area during the match. The Lineman may interact with the robot or any game pieces inside the robot start box only when the base of the robot identifier flag is [inside](#) the robot start box defined by the outside edge of the tape line.
26. The Lineman may not be touching the robot or any part of the field when the driver is touching the joystick.
- j. The Driver must maintain “hands off” the controller while the Lineman is
  - i. loading game pieces onto the robot,
  - ii. manipulating game pieces in the robot start box, or
  - iii. manipulating the robot during autonomous setup period.

The joystick must be placed on the “hands off” pedestal before the Lineman touches the robot and remain there during periods of interaction with the robot.

- k. The Lineman may not touch ANY game pieces or ANY part of the field that is in the field of play and outside of the robot start box.

### 3.8 Scoring

- a. All points are determined at the end of the match except for the autonomous delivery task (see Section 3.8.2 for further details).
- b. Any game piece that the robot or Lineman is touching at the end of the match does not score. The only exception is that a robot may be touching part of a line other than a line segment in a scoring position.
- c. The 4KV residential power line, lowest 345KV transmission power line, conduit trenches, debris disposal staging area and dumpster within a quadrant are all owned by the team assigned to the quadrant for the match and all items scored in these areas will benefit the team assigned to the quadrant (i.e., the local power grid).
- d. The mid and upper 345KV transmission lines are all accessible by any team and “ownership” of the power line is established upon making the first valid connection to another transmission line tower. The referee will indicate the line “ownership” by an appropriate colored flag on the corner transmission line tower.
- e. Three (3) 138KV distribution power lines, six residential transformers, and four substation transformers are assigned to the team and color-coded to match the assigned team color for the match. These items can be scored in any valid scoring location on the field regardless of the quadrant.

#### 3.8.1 Scoring Summary

Task Completed	End of Match Location	Points Each	Max # Possible Per Team	Max Pts Per Team
<b>Ground Debris</b>				
Ground debris cleared	Ground debris stored inside the team’s debris disposal staging area.	20	12	360
Ground debris removed	Ground debris stored inside the team’s dumpster.	30	12	
<b>Power Lines</b>				
345KV (Lower) Power Line Segment Connected (Team Assigned)	A “team assigned” power line segment connected at same phase level between two transmission line towers and not grounded between them (not touching floor or tower).	50	2	100
345KV (Mid) Power Line Segment Connected	Power line segment connected at same phase level between two transmission line towers and not grounded between them (not touching floor or tower).	70	8	560
345KV (High) Power Line Segment Connected	Power line segment connected at same phase level between two transmission line towers and not grounded between them (not touching floor or tower).	100	8	800
138KV Power Line Connected	(One end of) Power line connected to transmission line tower or distribution line tower, at any phase position.	40	4	320

138KV Power Line Segment Connected	Power line segment is connected between transmission line tower and distribution line tower at same phase position.	80	4	
4KV Power Line Segment Connected	Power line segment connected between two residential power poles and not grounded between them (not touching house or floor).	30	3	90
<b>Conduit</b>				
Conduit Pipe Installed	Electrical conduit pipe installed in a conduit trench within the team's quadrant.	20	9	180
<b>Transformers</b>				
Residential Transformer Installed	Residential Transformer installed on any residential power pole.	40	6	240
Substation Transformer Installed	Substation Transformer installed at any substation receiving pad.	60	4	240
<b>Autonomous Delivery</b>				
Autonomous Delivery Completed	Transmission line insulator autonomous delivery was successful.	200	2	400
<b>Bonuses</b>				
Autonomous Delivery Multi-Site Bonus	Transmission line insulator autonomous delivery was successful to both unique destinations.	50	1	50
Flexibility Bonus	Team completes ALL installations specified for Flexibility Bonus in section 3.8.3	100	1	100
<b>TOTAL POSSIBLE POINTS PER TEAM PER MATCH</b>				<b>3440</b>

### 3.8.2 Autonomous Delivery Scoring

The Autonomous Delivery task is judged by the referee in real-time during the match.

Refer to Section 3.7.10 for details of the expected sequence and evaluation of delivered successfully.

- a. The Autonomous Delivery task is scored as “successful” when
  - the driver touches the joystick on the hands-free platform, and
  - the robot is no longer touching the payload (spare tower insulator), and
  - the payload was delivered successfully at the base of the designated tower.
- b. The payload must be delivered prior to the end of the autonomous period (i.e., touching the joystick).
- c. If the driver picks up the joystick or touches it prior to the delivery of the payload, then the payload does not score. That is, the driver cannot initiate the final action that “scores” the payload.

### 3.8.3 Bonuses

- a. A 50-point Autonomous Bonus will be applied to the final match score if a team is successful on two autonomous delivery tasks to unique destinations. See Section 3.7.10 for details.
- b. A 100-point Flexibility Bonus will be applied to the final match score if a team completes ALL the following:
  6. One segment of any single power line (345KV, 138KV or 4KV) is connected.
  7. One conduit trench is filled (with three pipes).
  8. One substation transformer is installed.
  9. One ground debris item is removed (i.e., placed in dumpster).

### 3.8.4 Scoring Definitions

**Power Line segment “connected”** – when a power line (rope) is supported by the same phase level insulator (hook or post) on two like towers or poles (transmission, distribution, residential) and the segment between the towers is not grounded. A connected power line segment may touch other power lines and still score.

**Grounded** – when a power line touches the ground (floor), a house, a robot or an uninsulated part of a tower/pole.

**Power Line “connected”** – One end of a power line (rope) is supported by the insulator of a tower or pole. NOTE: two transmission towers and four residential poles have power lines that are pre-connected at the beginning of each match.

**Residential transformer “installed”** – when the transformer is attached to the residential power pole (via Velcro).

**Substation transformer “installed”** – when one 6x6 side of the substation transformer is touching the base of the tower flush and the transformer sits within the boundaries of the receiving pad.

**Conduit pipe “installed”** – when the entire length of pipe is resting on the bottom of the trench.

**Resting** – touching such that the entire weight of the object is supported by what it rests on.

**Inside** – within the imaginary infinite vertical planes defined by the innermost sides of a container/area or the inner edge of a tape line defining the boundaries of an area. The robot start box is the exception where the boundaries are defined by the outer edge of the tape line.

### 3.8.5 Sample Score Sheet

Red		Green	
M _____	F _____	M _____	F _____
Team _____		Team _____	
Score _____		Score _____	
<input type="checkbox"/>	Ground Debris - Cleared	<input type="checkbox"/>	Ground Debris - Cleared
<input type="checkbox"/>	Ground Debris - Removed (in bin)	<input type="checkbox"/>	Ground Debris - Removed (in bin)
<input type="checkbox"/>	4KV Residential Line Segments Connected	<input type="checkbox"/>	4KV Residential Line Segments Connected
<input type="checkbox"/>	138KV Line Segments - Connected	<input type="checkbox"/>	138KV Line Segments - Connected
<input type="checkbox"/>	138KV Line Segments - Segment Connected	<input type="checkbox"/>	138KV Line Segments - Segment Connected
<input type="checkbox"/>	345KV Line Segments Connected Lower	<input type="checkbox"/>	345KV Line Segments Connected Lower
<input type="checkbox"/>	345KV Line Segments Connected Middle	<input type="checkbox"/>	345KV Line Segments Connected Middle
<input type="checkbox"/>	345KV Line Segments Connected Upper	<input type="checkbox"/>	345KV Line Segments Connected Upper
<input type="checkbox"/>	Residential Transformer Installed	<input type="checkbox"/>	Residential Transformer Installed
<input type="checkbox"/>	Sub-Station Transformer Installed	<input type="checkbox"/>	Sub-Station Transformer Installed
<input type="checkbox"/>	13KV Conduit Trench A Pipe Installed	<input type="checkbox"/>	13KV Conduit Trench A Pipe Installed
<input type="checkbox"/>	13KV Conduit Trench B Pipe Installed	<input type="checkbox"/>	13KV Conduit Trench B Pipe Installed
<input type="checkbox"/>	13KV Conduit Trench C Pipe Installed	<input type="checkbox"/>	13KV Conduit Trench C Pipe Installed
<input type="checkbox"/>	Autonomous Transport Complete - Center Tower	<input type="checkbox"/>	Autonomous Transport Complete - Center Tower
<input type="checkbox"/>	Autonomous Transport Complete - Mid Tower	<input type="checkbox"/>	Autonomous Transport Complete - Mid Tower
Ref _____	Driver _____	Ref _____	Driver _____

### 3.9 Glossary of Terms

**Transmission Line Tower** – a tower positioned along the center diagonal of the field that carries three-phase 345KV transmission power lines. Transmission power lines are pre-connected to the towers in two corners of the field. Substation transformer receiving pads exist near the base of the towers in the corners of the field.

**Transmission Line Transfer Tower** – a single transmission line tower in the center of the field that provides termination points for both three-phase 345KV transmission power lines and three-phase 138KV distribution power lines.

**Distribution Line Tower** – a medium sized tower located at the intersection of two underground conduit trenches which provides termination points for three-phase 138KV distribution power lines.

**Substation transformer** – a 4x4x6 box-shaped game piece to be installed by the robot at the base of select transmission line and distribution line towers.

**Substation Transformer Receiving pad** – a designated location at the base of select Transmission Line Towers and Distribution Line Towers where substation transformer game pieces can be installed.

**Conduit Trench** – a narrow slot on the slightly raised ramps at ground level where electrical conduit pipes are inserted.

### 3.10 Example Scoring Positions

#### Conduit Pipes

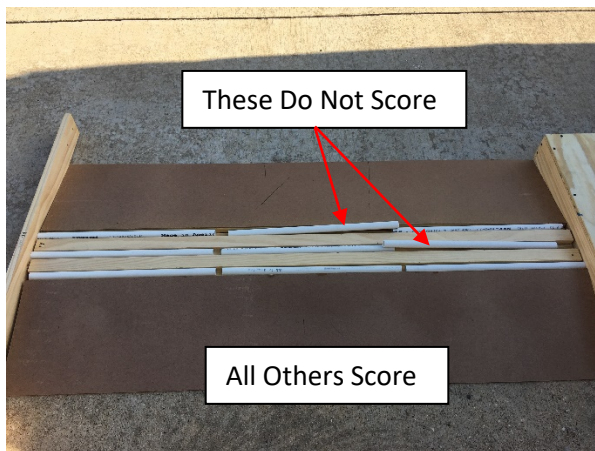
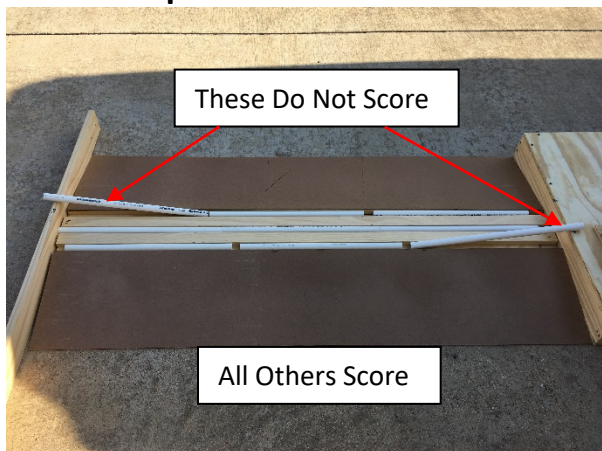

#### Debris Removal (Dumpster)

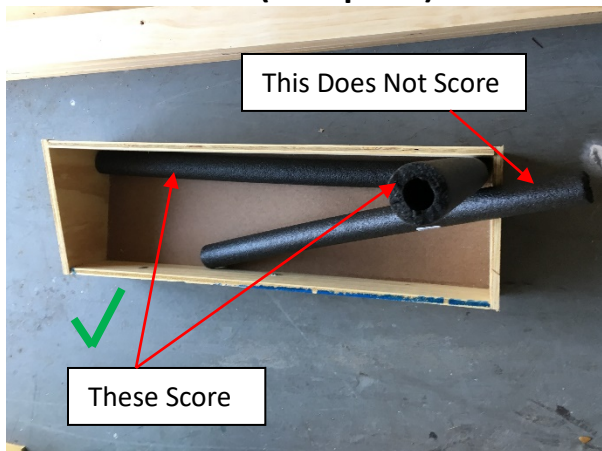

## Residential Transformer





## Substation Transformers

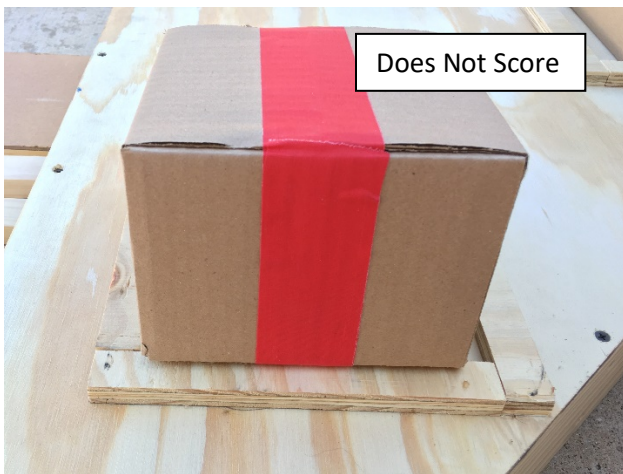

### 4KV Residential Lines

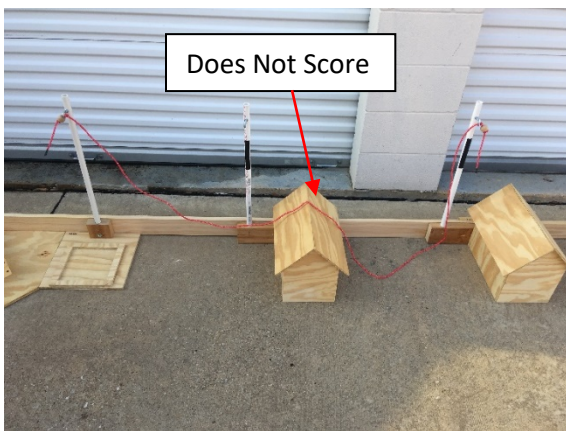
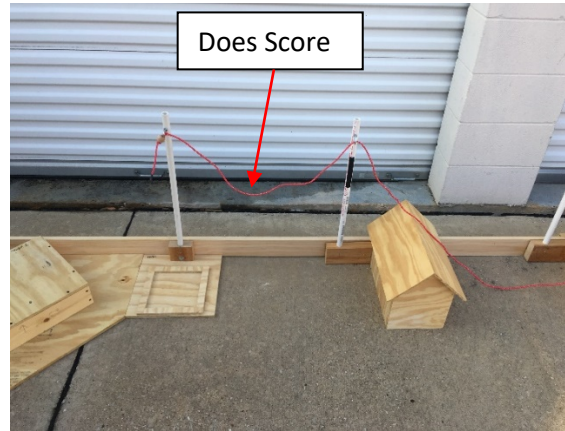
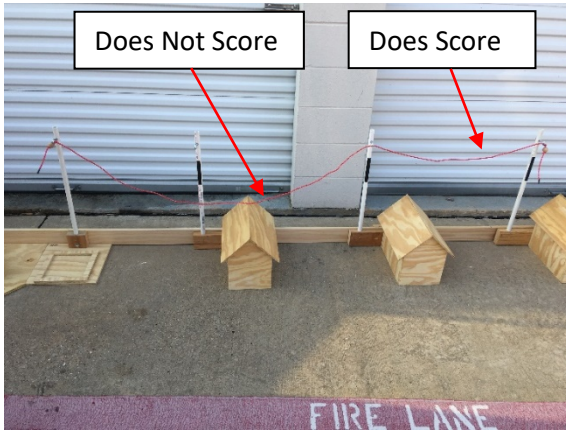
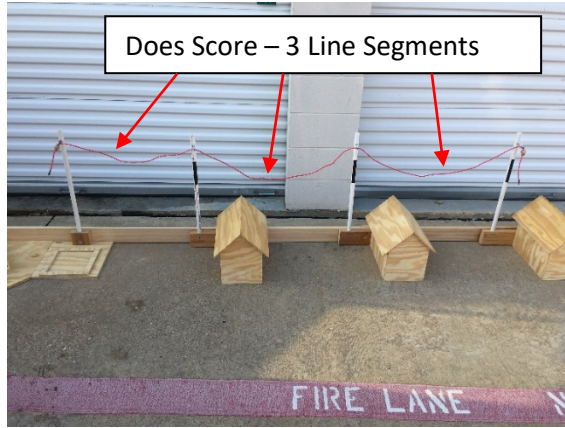
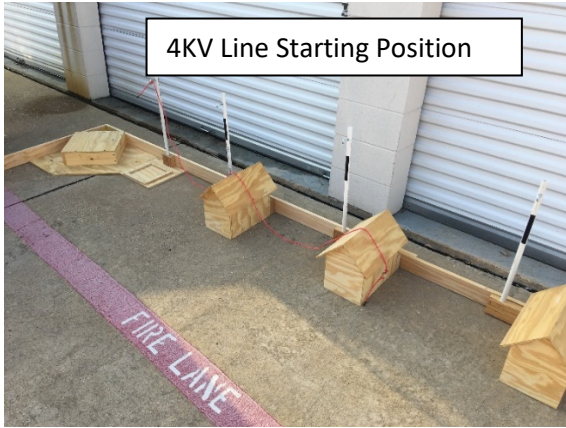

## Section 4 Awards and Judging

### 4.1 Head-to-Head Competition Judging

The head-to-head competition results for a team are dependent on the following criteria:

- The Team Demographics form must be completed and submitted by the participating team prior to competing
- An Engineering Notebook must be submitted by the participating team prior to competing
- All team members (students, teachers, mentors) must individually register in the BEST National Registry prior to competing on Game Day. Access the registry from the BEST website after Sep 7, 2019.
- A participating team must be compliant with the General Rules (constraints, etc.) and successfully pass the Robot Compliance Check prior to competing
- The Final head-to-head competition ranking is determined through robot performance using the Game Specific scoring rubric defined in Section 3 Game Specific Rules.

Any team that does not meet these criteria may be eliminated from consideration of awards and/or advancement.

### 4.2 The BEST Award

The BEST Award is presented to the team that best embodies the concept of *Boosting Engineering, Science, and Technology*. This concept recognizes that inclusiveness, diversity of participation, exposure to and use of the engineering process, sportsmanship, teamwork, creativity, positive attitude and enthusiasm, and school and community involvement play significant roles in a team's competitive experience and contribute to student success in the competition beyond winning an award.

In accordance with the BEST philosophy, **materials submitted by teams must be the work of students.** The involvement of student peers in auxiliary roles to support a school's official BEST team – i.e., journalists, photographers, artists, musicians – is encouraged.

Space constraints at each regional championship site will determine the number of teams that can compete for the BEST Award at the championship (check with the specific guidelines published by each regional championship). For a team to be eligible to compete for the BEST Award at any of the regional championships, the team: (1) must have placed in the top 3 teams in the BEST Award judging at their local hub competition, and (2) must agree to compete in all five of the BEST Award component categories at the regional championship.

### 4.2.1 Judging Evaluation and Criteria

Evaluation of competitors will be based on the criteria outlined here. An evaluation score up to 100 possible points will be composed of the following components:

Component I - Engineering Notebook (mandatory for ALL teams)

Component II - Marketing Presentation (at hub's discretion for BEST Award inclusion)

Component III – Team Exhibit and Interviews (at hub's discretion for BEST Award inclusion)

Component IV - Spirit and Sportsmanship (mandatory for BEST Award)

Component V - Robot Performance (mandatory for BEST Award)

Hubs competitions are required to judge at least four of the five components using one of the three following scenarios:

Scenario 1: **(preferred)**

Judged Components	Point Value
Engineering Notebook	30 points
Marketing Presentation	25 points
Team Exhibit and Interviews	20 points
Spirit and Sportsmanship	10 points
Robot Performance	15 points

*Total 100 points*

Scenario 2:

Judged Components	Point Value
Engineering Notebook	30 points
Marketing Presentation	25 points
Spirit and Sportsmanship	10 points
Robot Performance	15 points

*Total 80 points*

Scenario 3:

Judged Components	Point Value
Engineering Notebook	30 points
Team Exhibit and Interviews	20 points
Spirit and Sportsmanship	10 points
Robot Performance	15 points

*Total 75 points*

Refer to Section [5](#) for details on each of the Judged Components.

Refer to the **2019 Awards and Judging – Hub Logistics** document for the specific judging scenario at your local hub. Championship events will always employ Scenario 1. Teams that advance to a championship as eligible to compete for the BEST Award must compete in all five components.

## 4.2.2 Judging Procedure

- A distinguished team of judges from private and public sectors with technical and non-technical expertise will evaluate teams. Judges will serve on a rotation schedule.
- As each team completes a component, it will be assigned a component score that is the average of individual scores of the judges reviewing it.
- The organizing hub/championship may choose to drop the lowest judges' score for any judged component at their discretion.
- Teams should know in advance that scores among many teams frequently differ by only fractions of a point.

## 4.2.3 Judging Results

- Each team advancing to the regional championship will be provided with a copy of its score sheets following their local competition. Score sheets of non-advancing teams will be provided upon request.
- Teams advancing to the regional championship can use judges' comments to make improvements as they wish subject to the schedule restrictions of the regional championship (e.g., Engineering notebook due dates).

## 4.2.4 BEST Award Recognition

The teams ranked first, second, and third in the BEST Award judging will receive trophies superior to the teams finishing first through third in the Head to Head robot competition.

## 4.3 Simulink Design Award

The "BEST Simulink Design Award" sponsored by MathWorks is an award open to all teams participating in the competition. The award is presented to one team in each of the 3 BEST championship regions (South's, Texas, and Denver) that best applies the 'Simulink Support Package for VEX' based on the judging criteria below and their robot's performance in the competition. Any team using MathWorks MATLAB/Simulink to design their software (i.e., robot program) is eligible.

### 4.3.1 Applying for the Award

To apply for the award, teams are required to submit their best Simulink model and a short video describing their program design using Simulink. The entries must be submitted before 11 PM (local time) two weeks before their respective regional championship. See the **2019 Awards and Judging – Hub Logistics** document and the BEST Robotics website for more information on deadlines.

Information that teams need to provide when submitting their entry:

- Name of School
- BEST Hub (know which hub you belong to)
- Team Contact
- Team Contact Email Address (**important: all entries are tied to the email address**)
- # Students on the Team
- Simulink Model File (.slx file)
- Link to YouTube Video (3 minutes maximum)
- Brief Description (256 chars) of how the team used Simulink to program their robot

A PASSCODE is required to submit your entry. The PASSCODE will be the same as the current year's Game File Password. Contact your Hub to get the PASSCODE.

#### 4.3.2 Simulink Design Award Guidelines

- Only one entry per team is allowed.
- All teams can participate for the award within their region. There will 1 winner per region.
- Every entry should include the following items:
  - 1 Simulink model file (\*.slx)
  - 1 video link (use YouTube only)
- The Robot program must be created using Simulink. Submissions of programs designed using other software will not be accepted. The submitted Simulink file should not be a pre-built example model or the default program. It should be your own program or a modification of the existing examples or default program.
- The video should be no more than 3 minutes in length and include at least a 1.5 minute overview about the program design (e.g. a screencast of the Simulink model with voice over).
- Multiple submissions may be made by a team prior to the submission deadline always using the same email address during submission. Only the last submitted entry will be scored.
- Final submissions for this award must be uploaded at [http://www.bestinc.org/simulink\\_award/form.php](http://www.bestinc.org/simulink_award/form.php) before the stated deadlines.

#### 4.3.3 Simulink Design Award Evaluation

The award will be given to one team from each region and be based on the judging criteria and robot performance in the competition. The following criteria will be used for judging each entry using a maximum 100pt scale. The Simulink model is worth up to 70 points and the video is worth up to 30 points.

Simulink Model		Possible Points
Creativity	Innovative, creative and original work	5
Functionality	Error-free and designed to achieve the game tasks	10
Software Design Practices	Best practices like commenting, block naming, etc.	15
Difficulty and Mastery	Level of Simulink knowledge demonstrated in executing the tasks	20
Readability	Clean, organized and easy to comprehend	15
<b>TOTAL</b>		<b>70</b>

<b>(YouTube) Video</b>		<b>Possible Points</b>
Creativity	Interesting, innovative and informative	5
Quality of the video	Video making process and technical execution	10
Concept	Engaging, coherent and appropriate	10
Clarity	Message is clear and well-communicated	4
Adherence to Guidelines	Video length and content on Simulink usage	1
	<b>TOTAL</b>	<b>30</b>
	<b>Total Possible Points</b>	<b>100</b>

#### 4.3.4 Simulink Design Award Recognition

The winning teams will be awarded the following:

- Cash award
- Trophy with inscription 'BEST Simulink Design Award – by MathWorks', and
- a MathWorks hat for each team member

The winning teams from each region will be recognized on the BEST website ([www.bestinc.org](http://www.bestinc.org)) and their regional championship website.

#### 4.4 Additional Awards

Refer to Section 7 for details on additional awards provided at the Hub and Championship levels.

## Section 5 Judged Components

### 5.1 Engineering Notebook (30 Points)

#### 5.1.1 Notebook Requirements

- ALL participating teams are required to submit an Engineering Notebook at both the local competition and the regional championship following the requirements stated herein. All notebooks will be evaluated on a 30-point scale.
- For competitions having 32 or fewer total teams, the notebook scores of all teams will be used to determine which 4 teams earn a chance to participate in the single “wildcard” match. The winning wildcard team will be one of eight total teams that advance to the semifinals phase.
- For competitions having greater than 32 total teams, the notebook scores of all teams will be used to determine which 8 teams earn a chance to participate in one of the two “wildcard” matches. The two winning wildcard teams will be two of sixteen total teams that advance to the semifinals phase.
- The purpose of the notebook is to document the process the team used to design, build, and test their robot.
- The notebook may be delivered in electronic format (PDF only) or in physical format as determined by the local hub and regional championship.

NOTE: The preferred delivery format is electronic (PDF). Please see the [2019 Awards and Judging – Hub Logistics](#) document for the specified format and information on when and how the notebook is to be submitted.

- The notebook must meet the following specifications:
  - All physical notebooks must be submitted in a *standard* 3-ring binder with a maximum 2” ring size
  - A cover sheet / title page must identify the school, team name, teacher contact, and team number
  - 35 typed **single-sided** pages or less (note that title/cover page and Table of Contents page(s) will not be counted as part of the 35 pages)
  - Standard, 8 ½” x 11” paper, double-spaced, 1” margins, and Times New Roman (preferred) or similar business-style font no smaller than 12 pt. Single-spacing is acceptable in tables and outlines.
  - Teams may include a supplemental appendix of no more than 20 double-sided sheets (40 total pages) of information. The appendix may include support documentation such as drawings, photos, organization charts, minutes of team meetings, test results, etc. *This material should directly support the process described in the primary document and NOT reflect activities related to community or promotional efforts, spirit development, or team building.*



## 5.1.2 Notebook Evaluation

- The notebook will be judged on the documentation of the team's:
  - **Implementation of the Engineering Design Process**
    - Evidence that the engineering process was effectively used.
  - **Research Paper**
    - Correlation between the current year's game theme and how related technological practices or scientific research is being used at a company/industry/research lab in the team's state or region; Any information related to the game theme, such as history, famous inventor(s), or major milestones; Analysis of the game theme/problem and the related technology's impact on the human experience, our needs, adaptations, and progress with solutions throughout history; Creativity in linking the game theme to appropriately related science/technology content; Proper use of grammar and composition throughout the paper; citations of sources used to gather information for the paper
    - The research paper must be a minimum of 2 pages and maximum of 5 pages (of the allotted 35 pages)
  - **Brainstorming Approaches**
    - How well organized and productive was the brainstorming approach used? How well was the brainstorming approach documented?
  - **Analytical Evaluation of Design Alternatives**
    - Use of analytical and mathematical skills in deciding upon and implementing design alternatives
  - **Offensive and Defensive Evaluation**
    - Analysis of the gaming strategies and design elements used to achieve specific team goals
  - **Software Development Process**
    - Evidence that a software development process was effectively used including
      - Project scope/requirements/specification ("what" the robot should do without stating how)
      - Design ("how" the software will achieve the scope/requirement/specification)
      - Implementation (tools, methods and techniques used in your programming)
      - Test/Verification (methods used to verify correct operation of the robot program)
      - Deployment (source code management, release, download frequency, etc.)
    - Evidence that software design methods/techniques were explored and utilized.
  - **Safety**
    - Evidence that safety training took place and safe practices were followed to prevent students' misuse of tools and other devices/equipment that may result in personal injury or damage to property

- **Support Documentation**
  - Proof of team members' (students, teachers, mentors) individual registration at the BEST National Registry (opens Sep 7, 2019; see BEST website); this can be a simple roster with date of registrations
  - Team organization, team minutes, test results, CAD/other drawings, photos, etc. that support the main document
- **Overall Quality and Completeness of Notebook**
  - Organization, appearance, adherence to specifications, quality of content

## 5.2 Marketing Presentation (25 Points)

### 5.2.1 Purpose and Context

- The purpose of the Marketing Presentation is for students to learn how to address the needs of a potential client, share product and brand information and navigate the business environment.
- The Team's Role: To create a company that designs and manufactures robots (the product).
- The Judge's Role: To serve as the client who is looking to purchase a robot(s) to solve a problem(s).
- The Problem: Refer to Section 3 Game Specific Rules and research real-world relevance in the manufacturing sector.

The context for the presentation is as follows:

Your team is a business pitching your latest invention/product to a group of decision makers at BEST Inc. headquarters in response to a Request For Proposal (RFP). Your goal is to inform, persuade, and build trust between your company and your potential client.

Your company's brand promise will establish a shared understanding of the client's problem and how your product delivers the solution. The only details about the engineering team and the manufacturing process that need to be included are those that highlight the unique characteristics or how the characteristics differentiate your product from a competitor. Storytelling should be an important tool to add personality to your brand and create a stronger connection with your client.

BEST Inc. is very involved in community outreach. Share how your team, as a potential vendor embraces the same social responsibility.

To close the meeting, formalize an action statement for the client.

### 5.2.2 Marketing Presentation Guidelines

- A minimum of 4 and maximum of 8 students may participate in the room for the presentation. Each student present must have an active role in the presentation.
- Each BEST Award team will sign up for a presentation time to occur at a time designated by the local hub or regional championship.

- Only students may participate in the presentation/discussion, including setting-up and dismantling the presentations. Teachers, parents, mentors and other loving adults are not permitted to watch the presentation.
- The only printed or other materials that teams may give to the judges are a brochure and business cards. No gifts for the judges please.
- Robots and models may be used during the presentation for demonstration purposes.
- Teams should represent diversity in grades, gender, race, ethnicity and abilities. Teams are encouraged to share and demonstrate how their efforts are inclusive.
- Videotaping/photographing the presentation by students will be allowed; however, the person(s) handling recording devices will be counted in the maximum students allowed and therefore s/he will need to contribute to the presentation beyond capturing footage or images.
- The presentation format is the prerogative of the team.
- The team must provide any equipment it wishes to use or check with the local hub or championship for information about what equipment can be provided. See the **2019 Awards and Judging – Hub Logistics** for details of equipment provided at your hub/championship event.

### 5.2.3 Marketing Presentation Logistics

- There will be a check-in station in the general area of the presentation rooms where teams should check in prior to their time slot.
- The presentation/meeting will last for no more than twenty-five (25) minutes including any setup/breakdown. Teams are expected to begin with formal presentation.
- The meeting may become conversational with judges beginning to ask questions after ten (10) minutes of uninterrupted presentation by the team. The team may instigate a conversational format at any time, if desired. This is to encourage a business meeting atmosphere.
- Teams should use the judges' questions as cues and adapt their conversation. Be prepared to go off script and have a dialog exchange with the judges.
- At least five (5) minutes will be scheduled between presentation sessions to allow breaks for judges, rotations and additional time to confer without the team present.
- The local hub or championship will provide event-specific information (times, locations, etc.). Refer to the **2019 Awards and Judging – Hub Logistics** document for these additional details.

### 5.2.4 Marketing Presentation Evaluation

Presentations will be evaluated with consideration of:

- Introduction, Problem Solving for Clients and Closing the Sale
  - The team introduced themselves and explained their roles within the company.
  - The team (company) was knowledgeable and referenced the client's (judge's) needs listed in the Request For Proposal (the Game Story). The team defined the problem to solve.
  - The team explained their product's features and how the product's benefits solve the client's problem.

- The team proposed the product's cost, delivery, warranty and avenues for training of the client's workforce to operate the new product.
- The team included its social responsibility and sustainability of their company and the impact it has on their community.
- The team provided an action statement for the client.
- Brand Promise
  - The team created a consistent brand and brand promise.
  - The team clearly defined how the product is unique, desirable and produces a benefit(s) to the client.
  - The team provided a value proposition and how the value/trust can be acknowledged by the client.
  - The team expressed a mission statement for their company.
  - The team identified factors that differentiate their brand and product from the competition.
  - The team created a strong visual identity integrated into the brand, value and mission statement.
- Business Processes and Professionalism
  - The team met the 4-8 participant guidelines and was dressed professionally or theme-based.
  - The team was conversational and engaged in discussion.
  - The team utilized active listening techniques to keep the client engaged.
  - The team used storytelling or testimonials.
  - The team acted in a professional manner and was on brand.
  - The team used creative visual impact of presentation (i.e. infographics, etc.)

### 5.3 Team Exhibit and Judges Interview (20 Points)

- The Purpose of the Team Exhibit is for students to display a visual story of the team's outcomes and impact. It's designed within the annual theme and depicts the team's work in three realms: Robot/Product Features, Marketing/Branding, and Community Outreach/Advocacy.
- The Purpose of the Interview is to strengthen students' communication skills- (as listeners and speakers), validate their knowledge and understanding of the work done by the entire team; and spotlight unique design features, activities, or learnings.

#### 5.3.1 Exhibit and Interview Guidelines

- Refer to the **2019 Awards and Judging – Hub Logistics** document for standard table size at your local hub competition and availability. At championships, each team may be provided with a standard six-foot long table (approximately 29 inches wide) upon request.
- An 8' X 8' X 8' exhibit space will be allocated per team at your local hub and the championships. All exhibit content must remain within the defined exhibit area.
- All exhibits must display the national BEST Robotics logo in plain view
- Skirting for the table will not be provided.

- Teams are encouraged to use recycled, upcycled and repurposed items and to avoid using expensive store-bought display boards and structures. Consideration is given to creative and hand-made exhibit props.
- Each team should bring one extension cord and one power strip for any electrical needs. Refer to the **2019 Awards and Judging – Hub Logistics** document for possible electricity and electrical limitations at your local hub competition.
- Any audio-visual equipment and extra extension cords will be the responsibility of the team.
- Each team is responsible for the security of its own material.
- Each team is responsible for breakdown of its team materials and clean-up of its exhibit area following the awards ceremony on Game Day.
- All material should be clearly marked with the appropriate identification and contact information.
- Refer to the **2019 Awards and Judging – Hub Logistics** document concerning when and where team exhibits can be set up at your hub or championship competition.
- Candy and other food and drink items are not permitted at exhibits as complimentary handouts. Refer to the **2019 Awards and Judging – Hub Logistics** document concerning specific rules for your hub or championship competition.
- During the designated interview time, at least one student representative from the team must be present who is able to respond to informal questions asked about the exhibit. In addition, student representatives should be aware that judges may ask questions concerning robot design and construction. These questions will be part of the interview evaluation of the team.
- Teams should expect to be visited by three to four different judges during the interview period.
- Judges may also interview team members in the pit area and in the seating area.

### 5.3.2 Exhibit and Interview Evaluation

- **Exhibits** (10 points) will be evaluated on:
  - Social Responsibility
    - The team used visuals within the exhibit to effectively share outreach information, methods, audience and outcomes.
    - The team used testimonials and/or storytelling effectively to communicate impact in their school and community.
    - The exhibit reflects the diversity of the team (company) and their school and community (target audiences).
    - Team, Hub and national BEST sponsors are clearly displayed.
    - Hub and national BEST Robotics logos and/or branding are visible.
  - Product and Brand
    - The exhibit tells a story based on visual impression and brand promise is evident.
    - The team showcased information of their product (robot) in an informative manner.
    - The team embraced technology and used it in a meaningful and relevant way.
    - The exhibit is cohesive, engaging, interactive and creative.

- Electricity and Specifications for the Exhibit
  - The team calculated, demonstrated and communicated the energy needed to power their exhibit and used proper terminology.
  - The team adhered to all requirements set forth by the Hub/Championship (i.e. size limitations, student built, etc.)
- ***Interviews*** (10 points) will be evaluated on:
- Company Elevator Speech
  - Clearly defines what benefits the product (robot) delivers.
  - Explains outreach and social responsibility.
  - Conveys the company’s brand through tone and language.
- Testimonials and sharing the Brand
  - Students communicated the brand personality.
  - Students explained how their product (robot) provides brand advantage.
  - The team used testimonials to communicate impact in their school and community.
  - Outreach efforts and outcomes were shared.
- Game Theme and Learning Experience
  - Students clearly articulated an understanding of the game theme/problem.
  - The students showed evidence they were the primary designers and builders of their product (robot), exhibit and all materials.
  - Students clearly articulated lessons learned through the BEST experience.
  - Students communicated the impact of the BEST Robotics program on his/her path toward STEM or career choice.

## 5.4 Spirit and Sportsmanship (10 Points)

### 5.4.1 Spirit and Sportsmanship Guidelines

- Judges will evaluate this category on Game Day
- Judges will observe the spirit promoted by the team during their head-to-head competition matches as well as the team’s conduct throughout the day in the seating area, team exhibit area, game floor, and pit area

### 5.4.2 Spirit and Sportsmanship Evaluation

- Spirit includes the vigor and enthusiasm displayed by team representatives
- Teams can use posters, props, t-shirts, cheerleaders, musicians, mascots, costumes, and lower-frequency noisemakers to increase the level of spirit (Check the **2019 Awards and Judging – Hub Logistics** document to determine noise-maker restrictions for your local hub competition)
- Community involvement: number of team supporters present at competition (other than students)
- Sportsmanship includes outward displays of sportsmanship (e.g., helping other teams in need), grace in winning and losing, and conduct and attitude considered befitting participation in sports

- Overall team sportsmanship is also demonstrated by students (not mentors) making the majority of robot adjustments and repairs during the competition

## 5.5 Robot Performance (15 Points)

- The *Robot Performance* component will determine the final 15% of possible BEST Award points. These 15 points will be based on the total game points earned throughout the seeding phase of the head-to-head competition (prior to the semi-final phase) according to the following scale:
  - Team finishes in top 20% of all teams competing at hub 15 Points
  - Team finishes in top 40% of all teams competing at hub 12 Points
  - Team finishes in top 60% of all teams competing at hub 9 Points
  - Team finishes in top 80% of all teams competing at hub 6 Points
  - Team finishes in top 100% of all teams competing at hub 3 Points
  - Team is unable to score any points during the competition 0 Points
- Up to 15 Robot Performance points will be added to the total BEST Award points

## 5.6 BEST Robotics Brand Usage Guidelines for Teams

Although the BEST Award doesn't require teams to design websites or tee shirts or maintain a certain level of presence on social media, students are encouraged to explore options and we support their creativity. BEST Robotics also wants to ensure that our brand is presented in a clear and consistent manner across our footprint. Therefore, we ask students to follow these guidelines:

- Include the BEST Robotics national logo on all digital and printed materials.
- Team websites should include
  - On the homepage - the national logo and a link to national website
  - Storytelling from students (video or quote with pictures)
  - Testimonials from community leader (video or quote with pictures)
- Tee shirts should include the national logo, set apart from other sponsors or positioned above all other sponsors
- All social media posts during or about your team's outreach activities should include the hashtag: #BESTRobotics and tag @BESTRobotics.

## Section 6 Advancement to Regional Championship Competition

The total number of teams a hub will be allowed to send to a regional championship is determined by the regional championship. Traditionally this number is related to the number of teams competing at the hub, the total number of teams in the region, and the maximum number of teams that the regional championship venue can accommodate.

Advancing teams will be selected using the following priority order:

1. BEST Award 1<sup>st</sup> Place
2. Game 1<sup>st</sup> Place
3. BEST Award 2<sup>nd</sup> Place
4. Game 2<sup>nd</sup> Place
5. BEST Award 3<sup>rd</sup> Place
6. Game 3<sup>rd</sup> Place
7. BEST Award 4<sup>th</sup> Place
8. Game 4<sup>th</sup> Place
9. BEST Award 5<sup>th</sup> Place
10. BEST Award 6<sup>th</sup> Place
11. BEST Award 7<sup>th</sup> Place
12. etc.....

The list above is intended to illustrate the qualification order, not necessarily the exact number of teams advancing from each hub.

### Exception to the qualification order:

A hub has the option to advance a Game winner OR a BEST Award winner at their discretion IF the hub is limited in the number of advancing teams that can participate in the BEST Award at the regional championship, and IF a BEST winner also places as a Game winner.

For example, if a regional championship allows four advancing teams per hub, BUT only two advancing teams can participate in the BEST Award, AND a Game winner is also a BEST Award winner at the hub level, a hub could be forced to advance a 3<sup>rd</sup> place BEST Award team that cannot actually compete in the BEST Award at the Regional level. In such a case, the hub can opt to send the 3<sup>rd</sup> place Game winner instead of the 3<sup>rd</sup> place BEST Award winner.



## Section 7 Standard Required Awards

### 7.1 Hub-Level Awards

The following awards will be given at all BEST hub competitions:

#### **BEST Award**

Awarded to the team that best embodies the concept of ***Boosting Engineering, Science and Technology***. Winning the BEST Award is considered the highest achievement any team in the competition can accomplish. First, second, and third place finishes will be awarded.

#### **Head-to-Head Competition Award**

Awarded to the teams whose machines finish first, second, and third in the head-to-head robotics competition. In addition, fourth place “finalist” will also be awarded.

#### **Founders Award for Creative Design**

Awarded to the team that makes best use of the engineering process in consideration of offensive and defensive capabilities in machine design. Awarded in recognition of BEST founders Steve Marum and Ted Mahler.

#### **Most Robust Machine**

Awarded to the team whose machine requires the least maintenance during and between matches and is generally the sturdiest machine in the competition.

### 7.2 Regional Championship Awards

The following awards will be given at all BEST regional championships:

#### **BEST Award**

Awarded to the team that best embodies the concept of ***Boosting Engineering, Science and Technology***. Winning the BEST Award is considered the highest achievement any team in the competition can accomplish. First, second, and third place finishes will be awarded.

#### **Head-to-Head Robotics Competition Award**

Awarded to the teams whose machines finish first, second, and third in the head-to-head robotics competition. In addition, fourth place “finalist” will also be awarded.

#### **Founders Award for Creative Design**

Awarded to the team that makes best use of the engineering process in consideration of offensive and defensive capabilities in machine design; awarded in recognition of BEST founders Steve Marum and Ted Mahler.

### **Most Robust Machine**

Awarded to the team whose machine requires the least maintenance during and between matches and is generally the sturdiest machine in the competition.

### **BEST Simulink Design Award**

Awarded to one team in each of the 3 BEST regions (Denver, South's, Texas) that best applies the 'Simulink Support Package for VEX' based on the specified judging criteria and their robot's performance in the competition.